

# **FLX-AES3**

## AES3-to-everything Digital Audio Converter

User's Manual

**((en))**

## Table of Contents

|    |  |    |
|----|--|----|
| 1  | QUICK REFERENCE.....                           | 4  |
| 2  | INTRODUCTION.....                              | 5  |
|    | 2.1. Purpose.....                              | 5  |
|    | 2.2. Block diagram.....                        | 5  |
|    | 2.3. Box Contents.....                         | 6  |
|    | 2.4. Conventions used in this manual.....      | 6  |
| 3  | POSSIBLE SETUPS.....                           | 7  |
|    | 3.1. Available AUX cards.....                  | 7  |
|    | 3.2. Available FLX devices.....                | 8  |
|    | 3.3. FlexLink connection.....                  | 8  |
| 4  | AUDIO ROUTING.....                             | 9  |
|    | 4.1. Modes and indication.....                 | 10 |
|    | 4.2. Selecting the Route Mode.....             | 12 |
|    | 4.3. Remarks.....                              | 12 |
| 5  | CLOCK SETTINGS.....                            | 13 |
|    | 5.1. Clock sources and indication.....         | 13 |
|    | 5.2. Selecting the Clock Source.....           | 13 |
| 6  | REMOTE CONTROL.....                            | 15 |
|    | 6.1. Browser-based control.....                | 15 |
|    | 6.2. Command line control.....                 | 15 |
| 7  | ACCESSING INTERNALS.....                       | 16 |
|    | 7.1. Opening the device.....                   | 16 |
|    | 7.2. Inside view.....                          | 16 |
|    | 7.3. Installing AUX cards.....                 | 16 |
|    | 7.4. Variable DB25 pinout.....                 | 17 |
| 8  | DIP SETTINGS.....                              | 18 |
|    | 8.1. Base Device Config (DIP1..3).....         | 18 |
|    | 8.2. AUX Card Config (DIP4..6).....            | 20 |
|    | 8.3. AUX Card Channel Offset (DIP7..9).....    | 22 |
|    | 8.4. FlexLink Assignment (DIP7..9).....        | 22 |
| 9  | SPECIAL OPERATING MODES.....                   | 24 |
|    | 9.1. Version Display.....                      | 24 |
|    | 9.2. LED Test.....                             | 24 |
|    | 9.3. Interface Self-Test.....                  | 25 |
|    | 9.4. Firmware update.....                      | 25 |
| 10 | SPECIFICATIONS.....                            | 26 |
| 11 | ACCESSORIES.....                               | 26 |
|    | 11.1. Rack mount kits.....                     | 26 |
|    | 11.2. Additional (redundant) power supply..... | 26 |

---

|    |                                 |    |
|----|---------------------------------|----|
| 12 | APPENDIX.....                   | 27 |
|    | 12.1. Warranty.....             | 27 |
|    | 12.2. Manufacturer contact..... | 27 |
|    | 12.3. FCC Compliance.....       | 27 |
|    | 12.4. Recycling.....            | 28 |
|    | 12.5. About this document.....  | 28 |

1. QUICK REFERENCE

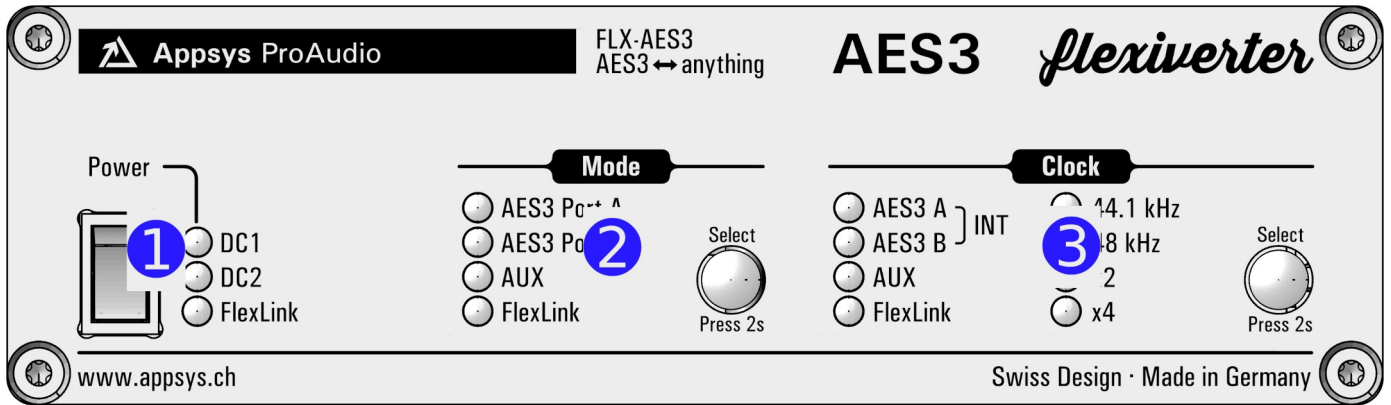

- 1 Power switch and "power good" indicators. LEDs light up blue when power is available on the respective port.
- 2 Mode indicators/selector. Long-press the "Select" button to change the audio routing between the interfaces. Wait four seconds to activate the selected mode.
- 3 Clock indicators/selector. Long-press the "Select" button to change the clock source and sample-rate. Wait four seconds to activate the selected mode.

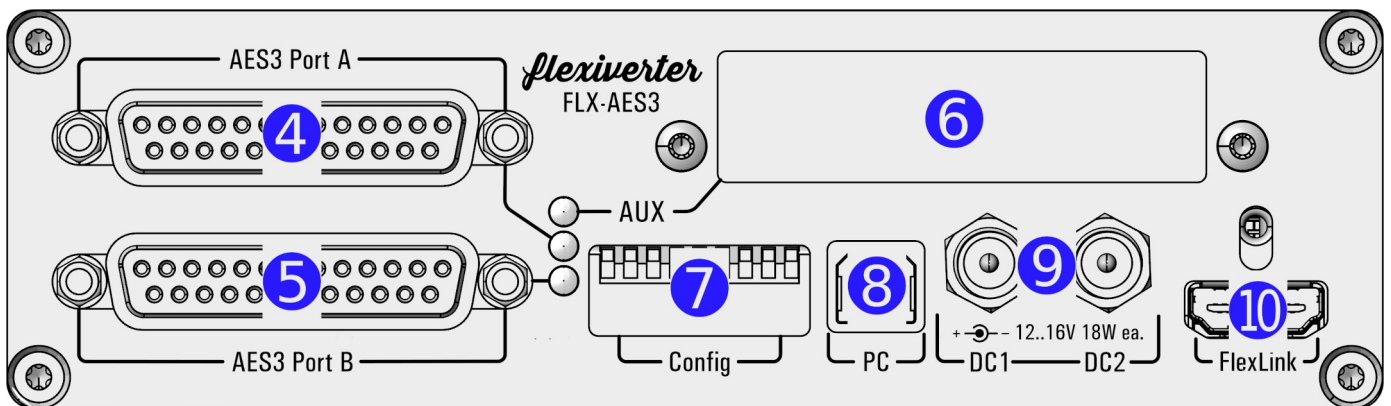

- 4 5 AES3 ports A (ch1-8) and B (ch9-16)
- 6 AUX slot. Accepts optional card for standalone use, or additional AES3 channels
- 7 DIP switches, mostly to control output data format. See [8. DIP Settings](#)
- 8 USB port (firmware update only, no audio)
- 9 Redundant DC input ports
- 10 FlexLink: optional connection to second flexiverter, or to multiverter.

## 2. INTRODUCTION

### 2.1. Purpose

The FLX-AES3 device is as digital audio converter, providing up to 16x16 channels of AES/EBU at samplerrates up to 192kHz. It can be used in different setups, depending on the user's needs:

- standalone, to convert between the built-in AES3 ports and an AUX card
- together with another flexiverter, connected via FlexLink. This enables for example up to 40x40 channels of AES3 to be converted.
- together with the multiverter, connected via FlexLink. This provides remote control, channel-wise routing and SRC (Sample Rate Conversion).

For a detailed description of possible configurations see [3. Possible Setups](#).



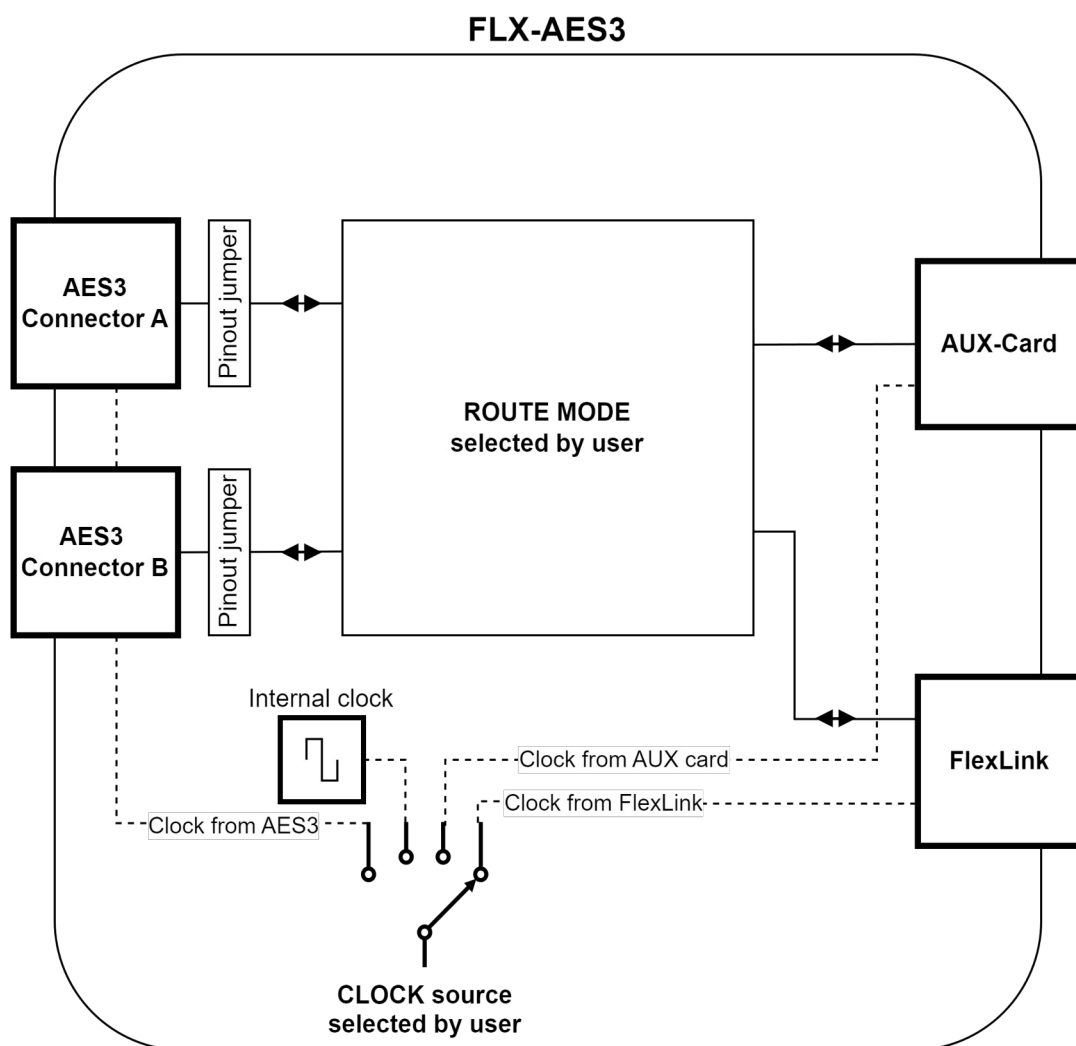

### 2.2. Block diagram



### 2.3. Box Contents

- 1 FLX-AES3 Converter
- 1 HDMI cable 0.5m / 1.7 ft with locking screws
- 1 Power supply
- 1 Power cord (country specific)
- This manual

### 2.4. Conventions used in this manual

- A button on the front is shown like this:  **Mode** or  **Clock**
- A LED is shown like this:  off /  on /  blinking





Filled circles with an exclamation mark indicates an action that must be performed ("Required").



A section marked with an "information" icon indicates a useful tip.

### 3. POSSIBLE SETUPS

The device can be used in three different setups, shown below:

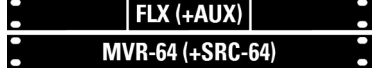
|  | SETUP   |  |   |
|--|---|--|---|
|  | FLX+AUX card  | Double-FLX   | flexiverter+multiplexer   |
|  |    |    |                            |
| <b>How it works</b>                                | Converts between built-in interface and the AUX card.<br><br>For a list of AUX cards, see <a href="#">3.1 Available AUX cards</a> . | Devices are connected via FlexLink cable.<br><br>Converts between one FLX(+AUX) and the other FLX(+AUX).                       | Flexiverter connected to multiplexer via FlexLink cable.<br><br>FLX(+AUX) serves as extension to the MVR-mkII |
| <b>Channels (all can be used at the same time)</b> | 16x16 AES3 @ 48kHz<br>16x16 AES3 @ 96kHz<br>16x16 AES3 @ 192kHz<br>or maximum capacity of the AUX card, whichever is less           | 40x40 AES3 @ 48kHz<br>40x40 AES3 @ 96kHz<br>40x40 AES3 @ 192kHz<br>converted to what is installed at the AUX card <sup>1</sup> | 448x448 from multiplexer plus 16x16 AES3 plus what the AUX card provides                                      |
| <b>Redundant power supply</b>                      | up to 2x  | up to 3x   | up to 3x  |
| <b>Battery-powered operation (DC 12-15V)</b>       | yes   | yes  | yes   |
| <b>Sample Rate Conversion</b>                      | no  | no   | yes (with SRC-128 card in Multiplexer)  |
| <b>Signal splitting</b>                            | yes (to AUX or FlexLink)  | no   | yes, to everything  |
| <b>Channel-wise routing</b>                        | no  | no   | yes, via MVR-64 (web, telnet or serial terminal)  |
| <b>Remote control</b>                              | no  | no   | yes, via MVR-64 (web, telnet or serial terminal)  |
| <b>Rack mount</b>                                  | 1U total  | 1U total   | 2U total  |

#### 3.1. Available AUX cards

At the time of writing (2025-01), the following AUX cards are available. More will come, please check [www.appsys.ch](http://www.appsys.ch) for updates.

| Item        | Description   |
|-------------|---|
| AUX-ADAT    | 16x16ch ADAT I/O (2x In+2x out). Supports also S/PDIF       |
| AUX-ADAT-64 | 64x64ch ADAT I/O (8x In+8x out). Connectors on breakout box |

<sup>1</sup> TypicalFLX-AES3+AUX-AES3 connected to FLX-AES3+AUX-\* (MADI/DANTE/etc.)

| Item          | Description   |
|---------------|---|
| AUX-AES3      | 8x8ch AES3 I/O on 1x DB25, fully transformer isolated             |
| AUX-DANTE     | 64x64ch DANTE network card  |
| AUX-MADI-COAX | 64x64ch MADI for coaxial cable (2xBNC connectors)                 |
| AUX-MADI-OPTO | 64x64ch MADI optical, SC connector (Multimode 125um 1310 nm)      |
| AUX-MADI-SFP  | 64x64ch MADI for SFP (Small-Factor Pluggable) modules             |
| AUX-MADI-TP   | 64x64ch Twisted-Pair (Cat5) MADI I/O for DiGiCo/Soundcraft/Studer |
| AUX-TDM       | 32x32 channel TDM/I2S, 3.3V LVCMOS I/O, ribbon cable connector    |
| AUX-WORDCLOCK | BNC wordclock I/O   |

### 3.2. Available FLX devices

At the time of writing (2025-01), the following FLX devices are available. More will come, please check [www.appsys.ch](http://www.appsys.ch) for updates.

| Item          | Description  |
|---------------|--|
| FLX-AES3      | 16x16 channel AES3 flexiverter (with AUX slot)                         |
| FLX-AES3/SRC  | 16x16 channel AES3 flexiverter with individual SRCs on the AES3 inputs |
| FLX-AES50     | 96x96 channel AES50 flexiverter (with AUX slot)                        |
| FLX-DANTE     | 64x64 channel DANTE flexiverter (with AUX slot)                        |
| FLX-DANTE/SRC | 64x64 channel DANTE flexiverter with bi-directional 64x64ch SRC        |
| FLX-MADI      | 128x128 channel MADI SFP & MADI coaxial module (with AUX slot)         |

### 3.3. FlexLink connection





The FlexLink connection is designed to connect Flexiverters with each other, or with the Multiverter. It provides:

- 192x192 channels bi-directional transmission of 24-bit uncompressed audio (fully transparent to AES3 compatible metadata bits)
- Super-low link latency of 4 samples (ca. 83µs)
- Dedicated, high-quality reference clock signal with automatic configuration
- Power supply for connected devices (to reduce cabling), alternatively serves as redundancy scheme when both devices are powered: in case of power failure, both devices keep working from the remaining power supply.
- Uses standard HDMI cables (with locking screws), to provide easy field replacement in case of defects.

#### **4. AUDIO ROUTING**

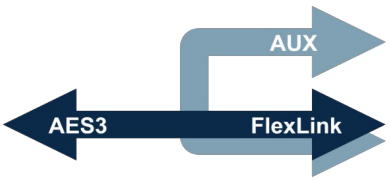
The flexiverter can operate in various routing modes, allowing you to pass audio between the available interfaces (AES3, AUX and FlexLink) in many different ways. The LEDs in the "MODE" section indicate the involved interfaces.

### 4.1. Modes and indication



| #  | Mode (route between)  | Operation (Example)   | Setup (blinking alternately, meaning "from goes to")  | Remarks  |
|----|---|---|---|--|
| #1 | <b>AES3 (+AUX)</b><br>⇔ FlexLink<br>         | <ul style="list-style-type: none"> <li>● AES3 Port A</li> <li>● AES3 Port B</li> <li>○ AUX</li> <li>● FlexLink</li> </ul> | <ul style="list-style-type: none"> <li>✱ AES3 Port A</li> <li>✱ AES3 Port B</li> <li>○ AUX</li> <li>○ FlexLink</li> </ul> | <ul style="list-style-type: none"> <li>■ AUX LED only active when card installed</li> </ul>  |
| #2 | <b>AES3</b><br>⇔ AUX<br>                     | <ul style="list-style-type: none"> <li>● AES3 Port A</li> <li>● AES3 Port B</li> <li>● AUX</li> <li>○ FlexLink</li> </ul> | <ul style="list-style-type: none"> <li>✱ AES3 Port A</li> <li>✱ AES3 Port B</li> <li>✱ AUX</li> <li>○ FlexLink</li> </ul> | <ul style="list-style-type: none"> <li>■ Only available with AUX installed.</li> <li>■ Channel offset in AUX can be changed<sup>2</sup></li> <li>■ Additional split of everything to FlexLink<sup>3</sup></li> </ul> |
| #3 | <b>AES3+FlexLink</b><br>⇔ AUX<br>          | <ul style="list-style-type: none"> <li>● AES3 Port A</li> <li>● AES3 Port B</li> <li>● AUX</li> <li>● FlexLink</li> </ul> | <ul style="list-style-type: none"> <li>✱ AES3 Port A</li> <li>✱ AES3 Port B</li> <li>✱ AUX</li> <li>○ FlexLink</li> </ul> | <ul style="list-style-type: none"> <li>■ Only available with AUX installed.</li> <li>■ Use with other FLX-AES3 in mode #1 for more channels</li> <li>■ Channel offset in AUX can be changed<sup>2</sup></li> </ul>   |
| #4 | <b>AES3 A ⇔ B</b><br>+split to AUX+FLX<br> | <ul style="list-style-type: none"> <li>● AES3 Port A</li> <li>● AES3 Port B</li> <li>● AUX</li> <li>○ FlexLink</li> </ul> | <ul style="list-style-type: none"> <li>✱ AES3 Port A</li> <li>✱ AES3 Port B</li> <li>✱ AUX</li> <li>○ FlexLink</li> </ul> | <ul style="list-style-type: none"> <li>■ Split and/or translate between Tascam and Yamaha pinout cables.</li> <li>■ Additional split of everything to FlexLink<sup>3</sup></li> </ul>                                |

2 The channel block where the data is inserted/extracted into the AUX stream can be changed. See 8.3 AUX Card Channel Offset (DIP7..9)

3 All incoming data is also split (output) to FlexLink: AES3 A+B are split to Lane 1 (ch1-64), AUX is split to Lane 2 (ch65-128), The split is not indicated on the LEDs for clarity but is always active.

| LED color         | Meaning   |
|-------------------|---|
| ○ off             | Interface not active / involved   |
| ● green           | IN and OUT valid  |
| ○ white           | OUT valid, but no IN detected   |
| ● red             | <p>No valid signal or no valid clock.</p> <ul style="list-style-type: none"> <li>◆ If the <b>clock</b> LEDs show red, make sure the clock mode is set correctly and a valid clock is supplied.</li> <li>◆ If the <b>clock</b> LEDs show green, the clock is ok but the input is not detected. Check the respective connection.</li> </ul> |
| ✱ red blinking    | Interface is currently booting and not yet active   |
| ✱ yellow blinking | <p>Mode setting active: Alternately blinking LEDs indicate the interfaces between which data is converted; constant lit LEDs indicate splitting destinations.</p> <p>Press MODE button again to cycle through available modes. After 4 seconds, the selected mode is applied automatically.</p>   |

## 4.2. Selecting the Route Mode



- Long-press the  **Mode** button until the LEDs are blinking yellow.
- Current routing mode is shown by alternately yellow blinking LEDs, indicating the interfaces where the signal is passed between.
- Press the  **Mode** button repeatedly to cycle between available modes, until the desired mode is shown.



Observe which LEDs are blinking alternately .The first phase indicates signal "source", the other "sink". Think of it as **"The blink alternates between source and sink"**

- After four seconds without interaction, selection mode is terminated and the current setting comes into effect.

## 4.3. Remarks

- Routing between the selected interfaces is always bi-directional, meaning that audio is passed between them both ways. A working bi-directional link shows  green for both interfaces. If the LED shows  white, the corresponding interface does only output data but no input on it has been detected. If the LED shows  red, the interface is not connected, or the clock is invalid or missing.
- When routing channels to the AUX or FlexLink interface, channels of AES3 Port A and B are concatenated together and appear on the FlexLink interface channels 1-16 and vice versa. The channels of the AUX card can either be mapped to the FlexLink interface directly after that (commencing at channel 17), or to a different block. See [8.4 FlexLink Assignment \(DIP7..9\)](#).
- Channel-wise routing and splitting (crosspoint switch/matrix) between all channels is possible when the flexiverter is connected to a multiverter. Routing is then done via the multiverter's web interface or via the command line.

## 5. CLOCK SETTINGS

### 5.1. Clock sources and indication

The flexiverter can be clocked from every interface (acting as clock slave), or can run on its internal clock (acting as clock master).

| Clock source            | "Clock" Indication (Example)  | Remarks   |
|-------------------------|---|---|
| <b>AES3(A)</b>          | <ul style="list-style-type: none"> <li><input checked="" type="radio"/> AES3 Port A      <input type="radio"/> 44.1 kHz</li> <li><input type="radio"/> AES3 Port B      <input checked="" type="radio"/> 48 kHz</li> <li><input type="radio"/> AUX                    <input type="radio"/> x2</li> <li><input type="radio"/> FlexLink            <input type="radio"/> x4</li> </ul>             | The first channel on port A which carries a valid signal is taken as clock source                                     |
| <b>AES3(B)</b>          | <ul style="list-style-type: none"> <li><input type="radio"/> AES3 Port A      <input type="radio"/> 44.1 kHz</li> <li><input checked="" type="radio"/> AES3 Port B      <input checked="" type="radio"/> 48 kHz</li> <li><input type="radio"/> AUX                    <input type="radio"/> x2</li> <li><input type="radio"/> FlexLink            <input type="radio"/> x4</li> </ul>             | The first channel on port B which carries a valid signal is taken as clock source                                     |
| <b>Internal ("INT")</b> | <ul style="list-style-type: none"> <li><input checked="" type="radio"/> AES3 Port A \    <input type="radio"/> 44.1 kHz</li> <li><input checked="" type="radio"/> AES3 Port B / INT <input checked="" type="radio"/> 48 kHz</li> <li><input type="radio"/> AUX                    <input type="radio"/> x2</li> <li><input type="radio"/> FlexLink            <input type="radio"/> x4</li> </ul> | Flexiverter acts as clock master.   |
| <b>AUX</b>              | <ul style="list-style-type: none"> <li><input type="radio"/> AES3 Port A      <input type="radio"/> 44.1 kHz</li> <li><input type="radio"/> AES3 Port B      <input checked="" type="radio"/> 48 kHz</li> <li><input checked="" type="radio"/> AUX                    <input type="radio"/> x2</li> <li><input type="radio"/> FlexLink            <input type="radio"/> x4</li> </ul>             | Only available with AUX installed. AUX card acts as clock master. Use an AUX-WORDCLOCK if you need BNC wordclock I/O. |
| <b>FlexLink</b>         | <ul style="list-style-type: none"> <li><input type="radio"/> AES3 Port A      <input type="radio"/> 44.1 kHz</li> <li><input type="radio"/> AES3 Port B      <input checked="" type="radio"/> 48 kHz</li> <li><input type="radio"/> AUX                    <input type="radio"/> x2</li> <li><input checked="" type="radio"/> FlexLink            <input type="radio"/> x4</li> </ul>             | Clock is taken from the peer device (Flexiverter or Multiverter)  |

| LED color  | Meaning   |
|--|---|
| <input type="radio"/> off                        | Interface not active / not involved   |
| <input checked="" type="radio"/> green           | Selected, locked and synced   |
| <input checked="" type="radio"/> red             | No valid clock. No input connected or no master clock signal detected   |
| <input checked="" type="radio"/> yellow blinking | Clock setting active. Press CLOCK button to go to the next clock source. After 4 seconds, selection mode is terminated and the selected mode comes into effect. |

### 5.2. Selecting the Clock Source

- Long-press the  **Clock** button until the LEDs are blinking yellow.
- Current clock source/modes is shown by blinking LED(s).

- Press the  **Clock** button repeatedly to cycle between the available clock sources. Depending on the source, you might need to select the desired sample rate ( \* 44.1 kHz or \* 48 kHz) and/or the appropriate multipliers ( \* x2 / \* x4).
- After four seconds without interaction, clock setting is automatically terminated and the selected clock source comes into effect.



When the samplerate is incorrectly set (e.g. 48k with 96k data), unwanted effects (double samples, zero samples, channel crosstalk etc.) may occur and might not be noticed immediately. Always double-check that the samplerate is set correctly on all involved devices!

## 6. REMOTE CONTROL

### 6.1. Browser-based control

This does not require any software to be installed. It works as hybrid app where the user interface is fetched from the web, and your browser talks to the device via USB connection.



Web control requires “Web Serial API” which is currently only available in **Chrome, Edge and Opera** on Windows and Mac. Not supported on mobile devices and Safari/Firefox.

To use web control,

- Connect the device to your computer using an USB cable
- Open your browser and go to [appsys.ch/remote](https://appsys.ch/remote)
- When the browser requests access to the serial port, give permission on the first port listed

### 6.2. Command line control

A command line is available via the USB serial port. To use it, you need a terminal software (Hyperterminal, PuTTY, minicom or similar) which can talk to a serial (“COM”) port.

To use the command line,

- Connect the device to your computer using an USB cable
- Open the terminal software. Select the first COM port which appears when plugging in the device
- Select 115200 bps, 8N1 as communication parameters
- To see what you’re typing, turn local echo “on” in the terminal software
- To see a list of available commands, type **he1p** at the **FLX>** command prompt

## 7. ACCESSING INTERNALS

### 7.1. Opening the device

- Required: Torx T10 screwdriver.
- Power off the device and detach all cables to avoid short-circuit or damage.
- Detach the device from the rack-mount kit.
- Remove the four top screws and the top cover by pulling it upwards:

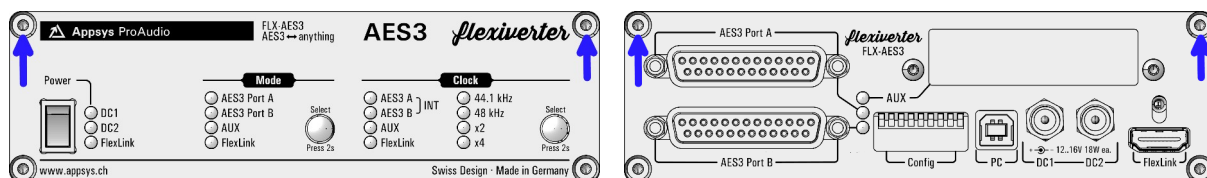

### 7.2. Inside view

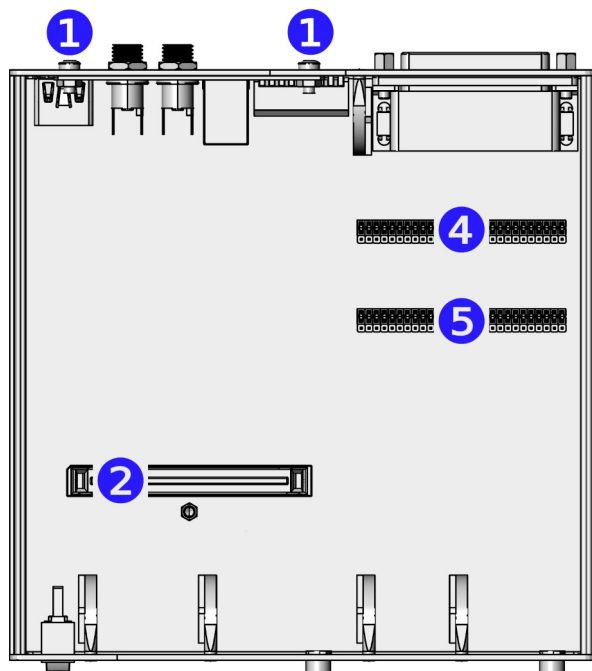

- ① Screws for AUX cover plate
- ② AUX card connector
- ④ Pinout select jumpers for lower DB25 connector (AES3 Port B)
- ⑤ Pinout select jumpers for upper DB25 connector (AES3 Port A)

### 7.3. Installing AUX cards

- Remove the screws holding the cover plate, and the blank cover plate ①
- Insert the AUX card from inside, using the supplied cover plate. Make sure it is correctly fitted to the card connector ②
- Secure the card using two cover screws ①
- The card has been installed correctly if you are able to select an audio routing mode involving AUX (long-press MODE button to enter Route Mode Selection).

### 7.4. Variable DB25 pinout

Historically, there are two different pin assignments for the AES/EBU DB25 connectors around, commonly known as "**Yamaha**" and "**Tascam**" style. The **FLX-AES3 supports both pinouts** by means of internal jumpers. Pinout can be set for both ports independently, meaning you could use the FLX-AES3 as cabling adapter. To select the pinout:

- Locate the jumper blocks 4 and/or 5 and move all jumper blocks (3 each) to the desired position.
- CAUTION: Take care when remove the jumper blocks, pulling both sides equally gently upwards. You might use a knife or a screwdriver to push the blocks upwards. **Make sure not to bend any pins!**
- The jumper position is not visible when the case is closed, but you can determine it from the color of the LEDs on the back side.

#### ► Tascam Pinout

Rear LED:

● red/● green/○ white  
(error/input ok/output only)

Used with:

- AES59 annex D
- Avid
- Digidesign
- PreSonus
- RME
- Tascam
- Universal

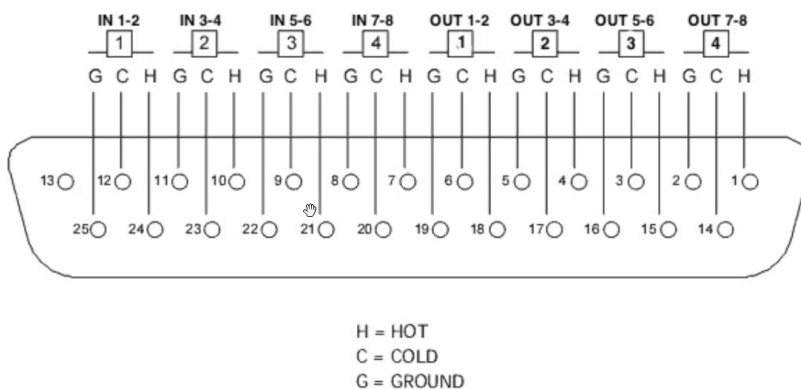

#### ► Yamaha Pinout

Rear LED:

● pink/● cyan/● beige  
(error/input ok/output only)

Used with:

- Apogee
- Mackie
- Lynx
- SSL
- Yamaha

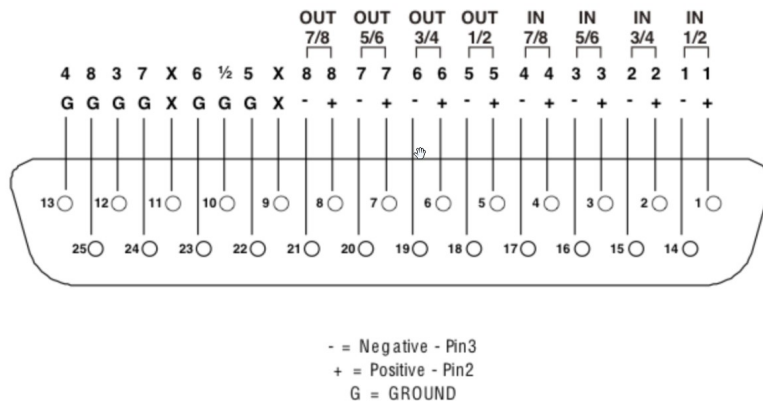

## 8. DIP SETTINGS

Fine-tuning of the flexiverter's built-in interface behavior and of the AUX card can be achieved via DIP settings on the back side. Changing the DIP settings will come immediately into effect. **Default setting: all switches up.**

### 8.1. Base Device Config (DIP1..3)

|                          |                          |  |                          |   |
|--------------------------|--------------------------|--|--------------------------|---|
| <input type="checkbox"/> | <input type="checkbox"/> | Single Wire (full channel count at 48k, 96k and 192k), professional format for metadata* | <input type="checkbox"/> | Clock source: Auto* <sup>4</sup>          |
| <input type="checkbox"/> | <input type="checkbox"/> | Double wire (half channel count), only in 96k and 192k modes                             | <input type="checkbox"/> | Clock source: Always input 1 <sup>4</sup> |
| <input type="checkbox"/> | <input type="checkbox"/> | Quad wire (quarter channel count), only in 192k mode                                     |                          |   |
| <input type="checkbox"/> | <input type="checkbox"/> | Single wire, SPDIF (consumer) format for metadata  |                          |   |

\* Default setting

- **Single Wire / Double wire / Quad wire:**

This is to maintain compatibility with legacy devices. Has only an effect for 88.2/96/176.4/192kHz data (44.1/48kHz data is always "single wire").

In **Single Wire** mode, always two channels are sent per AES3 connection. In 96kHz modes, they are sent at twice the speed as with 48kHz, and at quadruple speed in 192kHz modes. Supported by most up-to-date devices.

**Double Wire** mode is a legacy technique to send 96kHz data over 48kHz links, by halving channel count (one channel per AES3 connection). It is also sometimes found on 192kHz devices, allowing 192kHz data to be sent over 96kHz links.

**Quad Wire** mode takes this principle further by allowing 192kHz data to be sent over 48kHz links, by quartering the channel count (0.5 channels per AES3 connection).

- **SPDIF:** Metadata is sent as "consumer" (S/PDIF) format instead of "professional" (AES3) format. This does **ONLY** apply to metadata, the actual audio sample data is always transmitted in the same way.

4 From FLX device firmware 3.0 on. In older firmware versions, the setting is always "AUTO", and DIP3 is used to select "concat/separate" AUX data to FlexLink lanes (now DIP7)



Receiving **double-wire** or **quad-wire** data with incorrect DIP settings causes the flexiverter to make wrong assumptions of the size of disconnected channels, and may cause connected streams to appear at the wrong location.

- **Clock source:** Has only an effect when the clock source is set to "AES3 A" or "AES3 B".

When set to "**Auto**", the clock is taken from the first valid input on the respective connector, and may switch automatically when the input signal status changes.

When set to "**Always input 1**", the clock is always taken from line 1 on the respective connector. Use this setting if the inputs are coming from different devices, to ensure a reproducible clock source selection.

## 8.2. AUX Card Config (DIP4..6)

Many AUX card provide additional settings, which can be adjusted using these switches. The actual meaning depends on the type of AUX card installed:

|   |                            |   |  |   |   |  |
|---|----------------------------|---|--|---|---|--|
| <b>AUX-ADAT</b>   | <input type="checkbox"/> 4 | Channels 1-8:<br>ADAT format* <sup>5</sup>  | <input type="checkbox"/> 5   | Channels 9-16:<br>ADAT format* <sup>5</sup>   | <input type="checkbox"/> 6                          | Clock source:<br>Auto* <sup>6</sup>          |
|   | <input type="checkbox"/> 4 | Channels 1-2:<br>AES3/SPDIF fmt <sup>5</sup>  | <input type="checkbox"/> 5   | Channels 9-10:<br>AES3/SPDIF fmt <sup>5</sup> | <input type="checkbox"/> 6                          | Clock source:<br>Always input 1 <sup>6</sup> |
| <b>AUX-ADAT-64</b>  | <input type="checkbox"/> 4 | <input type="checkbox"/> 5  | ADAT output on all connectors 1-8 *  |   | <input type="checkbox"/> 6                          | Clock source:<br>Auto* <sup>6</sup>          |
|   | <input type="checkbox"/> 4 | <input type="checkbox"/> 5  | SPDIF/AES3 output on connector 1<br>ADAT output on connectors 2-8                        |   | <input type="checkbox"/> 6                          | Clock source:<br>Always input 1 <sup>6</sup> |
|   | <input type="checkbox"/> 4 | <input type="checkbox"/> 5  | SPDIF/AES3 output on conn. 1-2<br>ADAT output on connectors 3-8                          |   |   |  |
|   | <input type="checkbox"/> 4 | <input type="checkbox"/> 5  | SPDIF/AES3 output on conn. 1-3<br>ADAT output on connectors 5-8                          |   |   |  |
| <b>AUX-AES3</b>   | <input type="checkbox"/> 4 | <input type="checkbox"/> 5  | Single Wire (full channel count at 48k, 96k and 192k), professional format for metadata* |   | <input type="checkbox"/> 6                          | Clock source:<br>Auto* <sup>6</sup>          |
|   | <input type="checkbox"/> 4 | <input type="checkbox"/> 5  | Double wire (half channel count), only in 96k and 192k modes                             |   | <input type="checkbox"/> 6                          | Clock source:<br>Always input 1 <sup>6</sup> |
|   | <input type="checkbox"/> 4 | <input type="checkbox"/> 5  | Quad wire (quarter channel count), only in 192k mode                                     |   |   |  |
|   | <input type="checkbox"/> 4 | <input type="checkbox"/> 5  | Single wire, SPDIF (consumer) format for metadata  |   |   |  |
| <b>AUX-DANTE</b>  | <input type="checkbox"/> 4 | Enable AUX-DANTE card auto configuration (external WCLK yes/no, samplerate) depending on flexiverter settings |  |   |   |  |
|   | <input type="checkbox"/> 4 | Disable AUX-DANTE card auto configuration<br>Use this if you want to control behavior by Dante Domain Manager |  |   |   |  |
| <b>AUX-MADI-COAX</b><br><b>AUX-MADI-OPTO</b><br><b>AUX-MADI-SFP</b><br><b>AUX-MADI-TP</b> | <input type="checkbox"/> 4 | 96k frame* <sup>5</sup>   | <input type="checkbox"/> 5   | <input type="checkbox"/> 6                    | 64ch output* <sup>5</sup>                           |  |
|   | <input type="checkbox"/> 4 | 48k frame <sup>5</sup>  | <input type="checkbox"/> 5   | <input type="checkbox"/> 6                    | 57ch (use for DiGiCo stagebox control) <sup>5</sup> |  |

<sup>5</sup> Applies to output only, input-format is always auto-detected

<sup>6</sup> From FLX device firmware 3.0 on. Older firmware has always "AUTO"

|  |                               |                               |                          |
|--|-------------------------------|-------------------------------|--------------------------|
|  | <input type="checkbox"/><br>5 | <input type="checkbox"/><br>6 | 56ch output <sup>5</sup> |
|  | <input type="checkbox"/><br>5 | <input type="checkbox"/><br>6 | reserved                 |

|                |                               |                               |  |
|----------------|-------------------------------|-------------------------------|--|
| <b>AUX-TDM</b> | <input type="checkbox"/><br>4 | <input type="checkbox"/><br>5 | *TDM16. Each I/O line carries 16 channels of 32 bit audio data each (512 bits/BCLK cycles per LRCLK)     |
|                | <input type="checkbox"/><br>4 | <input type="checkbox"/><br>5 | TDM8. Each I/O line carries 8 channels of 32 bit audio data each (256 bits/BCLK cycles per LRCLK)        |
|                | <input type="checkbox"/><br>4 | <input type="checkbox"/><br>5 | TDM4. Each I/O line carries 4 channels of 32 bit audio data each (128 bits/BCLK cycles per LRCLK)        |
|                | <input type="checkbox"/><br>4 | <input type="checkbox"/><br>5 | TDM2 (Stereo). Each I/O line carries 2 channels of 32 bit audio data ea. (64 bits/BCLK cycles per LRCLK) |
|                | <input type="checkbox"/><br>6 |                               | *Left-justified, 32 bit per ch (24 bit audio data + 8 bits zero padding)                                 |
|                | <input type="checkbox"/><br>6 |                               | I2S-Format, 32 bit per ch (24 bit audio data + 8 bits zero padding)<br>Data is delayed by 1 BCLK cycle   |

|                      |                               |                                       |
|----------------------|-------------------------------|---------------------------------------|
| <b>AUX-WORDCLOCK</b> | <input type="checkbox"/><br>4 | True to samplerate* <sup>5</sup>      |
|                      | <input type="checkbox"/><br>4 | Always x1 (single speed) <sup>5</sup> |

\* Default setting

For cards not listed, refer to the manual of the respective card, or check for a newer version of this manual.

### 8.3. AUX Card Channel Offset (DIP7.9)<sup>7</sup>

For some configurations (i.e. multiple flexinverters with daisy-chained AUX-MADI cards), it may be desired to keep the incoming AUX data and insert/extract the converted data not at the beginning of the AUX stream, but on a different location. The location within AUX where the insertion/extraction of the converted data starts is called "offset" and can set below using DIP switches 7..9.



AUX Card Channel Offset via DIP7.9 is only available in modes where the AUX card is the primary conversion target. These modes are #2 and #3 (see 4.1 Modes and indication).

| DIP   | Offset | Description   |
|---|--------|---|
| <input type="checkbox"/> <input type="checkbox"/> <input type="checkbox"/><br>7 8 9 | 0*     | Audio data is copied from/to AUX starting from channel 0 (default)  |
| <input type="checkbox"/> <input type="checkbox"/> <input type="checkbox"/><br>7 8 9 | 8      | Audio data is copied from/to AUX starting at the specified offset (NOTE: numbers are halved at 96k, and quartered at 192k)<br><br>The AUX input channels below this offset are directly passed through to the AUX , i.e. are copied from AUX input to AUX output.<br><br>All channels exceeding the capacity of the AUX card are ignored. |
| <input type="checkbox"/> <input type="checkbox"/> <input type="checkbox"/><br>7 8 9 | 16     |   |
| <input type="checkbox"/> <input type="checkbox"/> <input type="checkbox"/><br>7 8 9 | 24     |   |
| <input type="checkbox"/> <input type="checkbox"/> <input type="checkbox"/><br>7 8 9 | 32     |   |
| <input type="checkbox"/> <input type="checkbox"/> <input type="checkbox"/><br>7 8 9 | 40     |   |
| <input type="checkbox"/> <input type="checkbox"/> <input type="checkbox"/><br>7 8 9 | 48     |   |
| <input type="checkbox"/> <input type="checkbox"/> <input type="checkbox"/><br>7 8 9 | 56     |   |

### 8.4. FlexLink Assignment (DIP7.9)

The FlexLink interface can transmit 192x192 channels, organized in three lanes with 64 channels each. When the device is used in double-FLX configuration, The channel and lane assignment can be adjusted to make sure that all interfaces and channels are mapped to the desired target on the peer FLX device.

<sup>7</sup> From firmware 2.9 on

- **Concat/Separate (DIP7)<sup>8</sup>**: Determines if AUX channels are seamlessly concatenated after AES3 A+B (commencing at channel 17), or if they are mapped to a separate block. "Concat" is useful e.g. with the AUX-AES3 card, to obtain a contiguous block total of 24x24 channels of AES3.
- **Lane Assignment (DIP8..9)<sup>8</sup>**: Controls the mapping of the blocks to the FlexLink lanes. This is useful in double-flexiverter configurations, to make each data appear on the desired interface on the peer device.



FlexLink Assignment is only available in routing modes where FlexLink is the primary conversion target<sup>7</sup>. For the FLX-AES3, these modes are #1 and #4 (see 4.1 Modes and indication)

| DIP  | Lane 1 (ch1-64) | Lane 2 (ch65-128) | Lane 3 (ch129-192) |
|--|-----------------|-------------------|--------------------|
| <input type="checkbox"/> 7 <input type="checkbox"/> 8 <input type="checkbox"/> 9 | AES3A+B(+AUX)*  | -                 | -                  |
| <input type="checkbox"/> 7 <input type="checkbox"/> 8 <input type="checkbox"/> 9 | -               | AES3A+B(+AUX)     | -                  |
| <input type="checkbox"/> 7 <input type="checkbox"/> 8 <input type="checkbox"/> 9 | -               | -                 | AES3A+B(+AUX)      |
| <input type="checkbox"/> 7 <input type="checkbox"/> 8 <input type="checkbox"/> 9 | AES3 A+B        | AUX               | -                  |
| <input type="checkbox"/> 7 <input type="checkbox"/> 8 <input type="checkbox"/> 9 | AUX             | AES3 A+B          | -                  |
| <input type="checkbox"/> 7 <input type="checkbox"/> 8 <input type="checkbox"/> 9 | AUX             | -                 | AES3 A+B           |
| <input type="checkbox"/> 7 <input type="checkbox"/> 8 <input type="checkbox"/> 9 | -               | AES3 A+B          | AUX                |

\* Default setting

<sup>8</sup> From firmware 3.0 on. In older firmware, concat/separate function was on DIP3, and DIP7..9 were used for FlexLink Lane assignment, but with different mappings. Contact us if you need to know the settings in firmware 2.9 and earlier.

## 9. SPECIAL OPERATING MODES

Special operating modes are accessible by *holding down the*  *button while switching on the device. Press*  *again to switch to the next mode:*



### 9.1. Version Display

The hardware and firmware version are indicated on the MODE and CLOCK leds<sup>9</sup>. The values are binary encoded. To get the version number, add all numbers from the "value" column where the corresponding LED is lit. The example below shows: hardware version 1, firmware version 2.6:

| Value | MODE<br>Hardware version:<br>green LEDS | CLOCK<br>Firmware version: white LEDS |       |
|-------|---|---------------------------------------|-------|
|       |   | Major                                 | Minor |
| 8     | ○                                       | ○                                     | ○     |
| 4     | ○                                       | ○                                     | ●     |
| 2     | ○                                       | ●                                     | ●     |
| 1     | ●                                       | ○                                     | ○     |

- Blinking LEDs mean that the currently installed firmware is a "beta" version. It is advised to upgrade to an official release version as soon as it is released.
- Press  again to proceed to LED test.



### 9.2. LED Test

- All LEDs on the front and on the back should show ○ white.
- Press  again to proceed to Interface Self-Test.

<sup>9</sup> In firmware 2.5. and earlier, the system was different: number of green LEDs = hardware version, number of pink LEDs = firmware major version, number of orange LEDs = firmware minor version.

### 9.3. Interface Self-Test

All built-in interfaces and the optional AUX card can be tested for correct operation by the user. This is done using the special self-test mode, in which the device outputs a special random test pattern on all channels. This pattern is looped back via an external cable into the corresponding inputs, where it is checked for consistency.

- Self-test mode is indicated with "CLOCK" showing INT/48kHz in  cyan color. The "MODE" LEDs indicate  red (error/no connection) or  green (loopback data received ok) for the respective interface.
- Make sure both ports "AES3 A" and "AES3 B" are set to the same pinout, matching the pinout of the loop-back cable.
- Connect "AES3 A" to "AES3 B" using the loop-back cable.
- If an AUX card is installed, connect all output ports of the AUX card to the respective inputs using a loop-back cable. Note: NOT supported with AUX-ADC, AUX-AES67, AUX-AVB, AUX-DANTE.

### 9.4. Firmware update

The firmware can be updated from any **Windows PC** over the rear **USB** port.

#### ► To update:

- Download the latest firmware from [www.appsys.ch/FLX-AES3](http://www.appsys.ch/FLX-AES3)
- Unpack the firmware package FLX-AES3-Firmware\_x.y.zip
- Connect your PC via USB to the flexiverter
- Power ON the device
- Run the **FLX-AES3\_Updater.bat** file from the firmware package and follow the instructions on the screen.
- Power cycle the device to effect the update.



Thanks to the special design of the updater, it is virtually impossible to damage ("brick") the device during update. If updating fails or is interrupted, restart the procedure. You can also go back to any older firmware version at any time

## 10. SPECIFICATIONS

| Parameter                | Value  |  |
|--------------------------|--|--|
| Dimensions               | 152x44x153mm (WxHxD) excluding connectors/buttons<br>152x44x163mm (WxHxD) including device-side connectors/buttons   |  |
| Weight                   | 590g   |  |
| Operating temperature    | 0..+55°C, non-condensing   |  |
| Storage temperature      | -40..+85°C, non-condensing   |  |
| Power consumption        | +15V DC, 9W max (18W to power two devices via FlexLink)<br>Triple-redundant input (2x DC, 1x via FlexLink)   |  |
| AES3 ports (A, B)        | Input and output fully transformer-isolated according to AES/EBU requirements<br>Maximum speed: 192kHz single-wire<br>Pinout: Tascam(AES) or Yamaha, selectable for each port via internal jumper blocks |  |
| Cable lengths            | FlexLink   | 1m / 3ft. max. recommended                   |
|                          | AES3   | 100m / 300 ft., depending on the peer device |
| Channel count            | 16x16 @ 48/96/192 kHz (Single-wire)<br>8x8 @ 96kHz, 8x8 @ 192kHz (Dual wire), 4x4 @ 192 kHz (Quad wire)<br>Additional AUX channels depending on AUX card   |  |
| Sample rates             | 44.1kHz, 48kHz, 88.2kHz, 96kHz, 176.4kHz, 192kHz<br>88.2/96kHz can operate in single-wire or double-wire mode<br>176.4/192kHz can operate in single-wire, double-wire or quad-wire mode                  |  |
| Latency                  | Conversion AES3 <> FlexLink: 2 samples<br>Conversion AES3 <> AUX: 4 samples plus AUX card latency<br>(depending on AUX card)   |  |
| Internal clock precision | Jitter: Phase RMS: <1ps, Peak-peak: <50ps.<br>Stability: ±25 ppm including all effects including aging, temperatur, supply, calibration, shock, vibration  |  |

## 11. ACCESSORIES

### 11.1. Rack mount kits

For integration in 19" racks, two kinds of rack mount kits / brackets are available:

- **RM-FLX1:** For mounting one FLX device into 1U 19" space
- **RM-FLX2:** For mounting two FLX devices into 1U 19" space

### 11.2. Additional (redundant) power supply

- **PWR-FLX:** Additional power supply to provide redundancy for single-FLX configurations
- **FlexLink Cable** 0.5m. HDMI cable with locking screws

## **12. APPENDIX**

### **12.1. Warranty**

We offer a full two (2) year warranty from the date of purchase. Within this period, we repair or exchange your device free of charge in case of any defect\*. If you experience any problems, please contact us first. We try hard to solve your problem as soon as possible, even after the warranty period.

\* Not covered by the warranty are any damages resulting out of improper use, willful damage, normal wear-out (especially of the connectors) or connection with incompatible devices.

### **12.2. Manufacturer contact**

Appsys ProAudio  
Rolf Eichenseher  
Bullingerstr. 63 / BK241  
CH-8004 Zürich  
Switzerland

[www.appsys.ch](http://www.appsys.ch)  
[info@appsys.ch](mailto:info@appsys.ch)  
Phone: +41 43 537 28 51  
Mobile: +41 76 747 07 42

### **12.3. FCC Compliance**

This equipment has been tested and found to comply with the limits for a class B digital device, pursuant to part 15 of the FCC Rules. These limits are designed to provide reasonable protection against harmful interference in a residential installation. This equipment generates, uses and can radiate radio frequency energy and if not installed and used in accordance with the instructions, may cause harmful interference to radio communications. However, there is no guarantee that interference will not occur in a particular installation. If this equipment does cause harmful interference to radio or television reception, which can be determined by turning the equipment off and on, the user is encouraged to try to correct the interference by one or more of the following measures:

- Reorient or relocate the receiving antenna
- Increase the separation between the equipment and receiver
- Connect the equipment into an outlet on a circuit different from that to which the receiver is connected
- Consult the dealer or an experienced radio/TV technician for help

This equipment has been verified to comply with the limits for a class B computing device, pursuant to FCC Rules. In order to maintain compliance with FCC regulations, shielded cables must be used with this equipment. Operation with non-approved equipment or unshielded cables is likely to result in interference to radio and TV reception. The user is cautioned that changes and modifications made to the equipment without the approval of manufacturer could void the user's authority to operate this equipment.

## 12.4. Recycling



According to EU directive 2002/96/EU, electronic devices with a crossed-out dustbin may not be disposed into normal domestic waste. Please return the products back for environment-friendly recycling, we'll refund you the shipping fees.

## 12.5. About this document

All trademarks mentioned in this document are property of the respective owners. All information provided here is subject to change without prior notice.

Document Revision: 6 · 2026-02-26

Copyright © 2021-2025 Appsys ProAudio · Printed in Germany

Rev 6: Added routing scheme arrows, clarified DIP settings, improved formatting

Rev 5: Added DIP settings of firmware 3.0

Rev 4: Added block diagram, AUX channel offset (Firmware 2.9)

Rev 3: Added AES3+FlexLink<> AUX routing mode to description

Rev 2: Remote control, AES3 clocksource taken from first valid channel

Rev 1: Initial release

IDENT 9.00.16143.00

# Declaration of Conformity

The manufacturer:

**Appsys ProAudio  
Rolf Eichenseher  
Bullingerstr. 63 BK 241  
CH-8004 Zürich  
Switzerland**

declares under sole responsibility that the products mentioned below:

**Flexiverter FLX-AES3**

meet the requirements of the following standards:

**EN 55024:2010  
EN 55032:2015 Class B  
EN 61000-3-2:2006/A1/A2:2009  
EN 61000-3-3:2009  
EN 61000-6-3:2007/A1:2011**

Therefore the product fulfills the demand of the following EC directives:

**73/23/EWG**

(Directive related to electrical equipment designed for use within certain voltage limits)

**89/336/EWG**

(Directive related to electromagnetic compatibility)

The devices are marked accordingly.

Zürich, 21.11.2021



Rolf Eichenseher (CEO)