

FLX-DANTE/SRC

Dante-to-anything

Digital Audio Converter with High-End SRC

User's Manual

((en))

Table of Contents

1	QUICK REFERENCE.....	4
2	INTRODUCTION.....	6
	2.1. Purpose.....	6
	2.2. Block diagram.....	6
	2.3. Box Contents.....	7
	2.4. Conventions used in this manual.....	7
3	TYPICAL SETUPS.....	8
	3.1. Available AUX cards.....	9
	3.2. Available FLX devices.....	9
	3.3. FlexLink connection.....	10
4	AUDIO ROUTING.....	11
	4.1. Modes and indication.....	11
	4.2. Selecting the Route Mode.....	13
	4.3. Remarks.....	13
5	CLOCK SETTINGS.....	14
	5.1. Clock sources and indication.....	14
	5.2. Selecting the Main Clock Source.....	15
	5.3. Display the clock status of both clocks.....	15
6	REMOTE CONTROL.....	16
	6.1. Browser-based control.....	16
	6.2. Command line control.....	16
7	ACCESSING INTERNALS.....	17
	7.1. Opening the device.....	17
	7.2. Inside view.....	17
	7.3. Installing AUX cards.....	17
8	DIP SETTINGS.....	18
	8.1. Base Device Config (DIP1).....	18
	8.2. AUX Card Config (DIP4..6).....	18
	8.3. AUX Card Channel Offset (DIP7..9).....	20
	8.4. FlexLink Channel Mapping (DIP7..9).....	21
9	SPECIAL OPERATING MODES.....	21
	9.1. Version Display.....	22
	9.2. LED Test.....	22
	9.3. Interface Self-Test.....	22
	9.4. Firmware update.....	23
10	SPECIFICATIONS.....	25
11	ACCESSORIES.....	26
	11.1. Rack mount kits.....	26
	11.2. Additional (redundant) power supply.....	26

12 APPENDIX.....27

12.1. Warranty.....27

12.2. Manufacturer contact.....27

12.3. FCC Compliance.....27

12.4. Recycling.....28

12.5. About this document.....28

1. QUICK REFERENCE

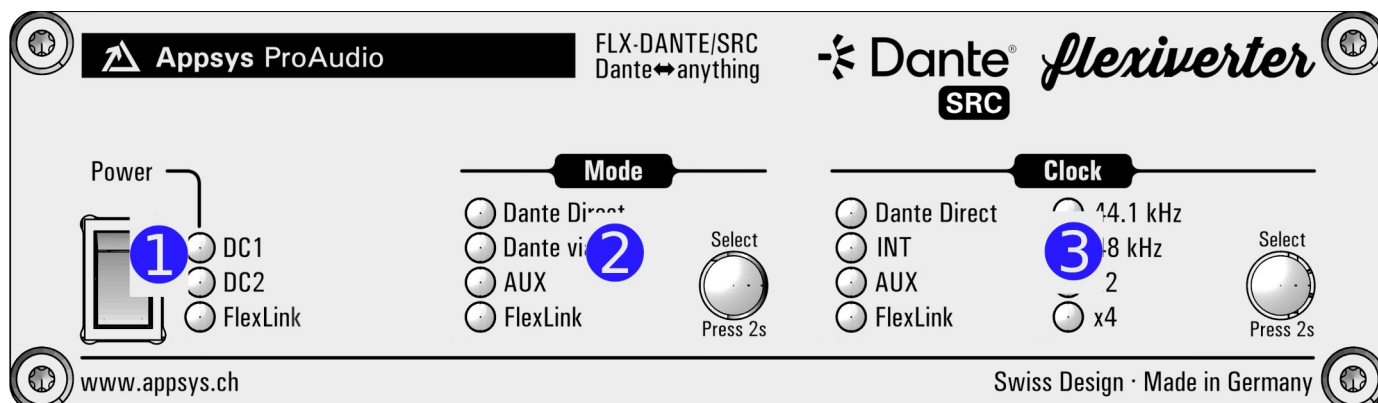

1	<p>Power switch and "power good" indicators. LEDs light up blue when power is available on the respective port.</p>
2	<p>Mode indicators/selector:</p> <ul style="list-style-type: none"> ■ Long-press the "Select" button to change the audio routing ■ The LEDs blink alternately between audio source and sink ■ Repeatedly press the button until the desired routing mode is set. Wait four seconds to activate the selected mode.
3	<p>Clock indicators/selector:</p> <ul style="list-style-type: none"> ■ Long-press the "Select" button to change the clock source and sample-rate of the device after the SRC (i.e. on the side of AUX and FlexLink) Wait four seconds to activate the selected mode. ■ Short-press the "Select" button to toggle the view of the sample rates between the Dante side (before the SRC) and on the AUX/FlexLink side (after the SRC).

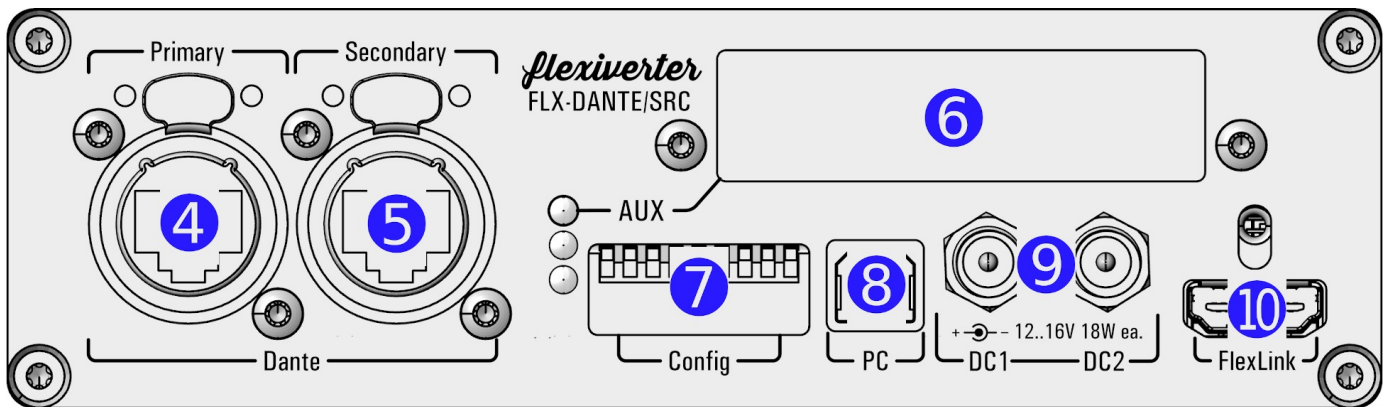

4 5	Dante Primary/Secondary ports. They are internally connected the SRC.
6	AUX slot. Accepts optional card for standalone use
7	DIP switches, mostly to control output data format. See 8. DIP Settings
8	USB port (firmware update and remote control, no audio)
9	Redundant DC input ports
10	FlexLink: optional connection to second flexiverter, or to multiverter

2. INTRODUCTION

2.1. Purpose

The FLX-DANTE/SRC device is a digital audio converter, providing a built-in Dante® network interface, individual Sample Rate Converters on the AES3 inputs and an additional slot for one AUX card. It can be used in different setups, depending on the user's needs:

- Standalone, to **convert between the built-in Dante and an AUX card** (Dante-to-anything). With AUX-DANTE card it acts as **Dante-to-Dante bridge**. This enables two different Dante networks to be kept physically separate, including separate IP address configurations, clock domains, etc. while audio is passed bidirectional between them.
- **Together with another flexiverter**, connected via FlexLink, for more channels (i.e. Dante with 64ch @ 96k)
- **Together with the multiverter**, connected via FlexLink. This provides remote control, channel-wise routing and much more.

For a detailed description of possible configurations see 3. Typical Setups



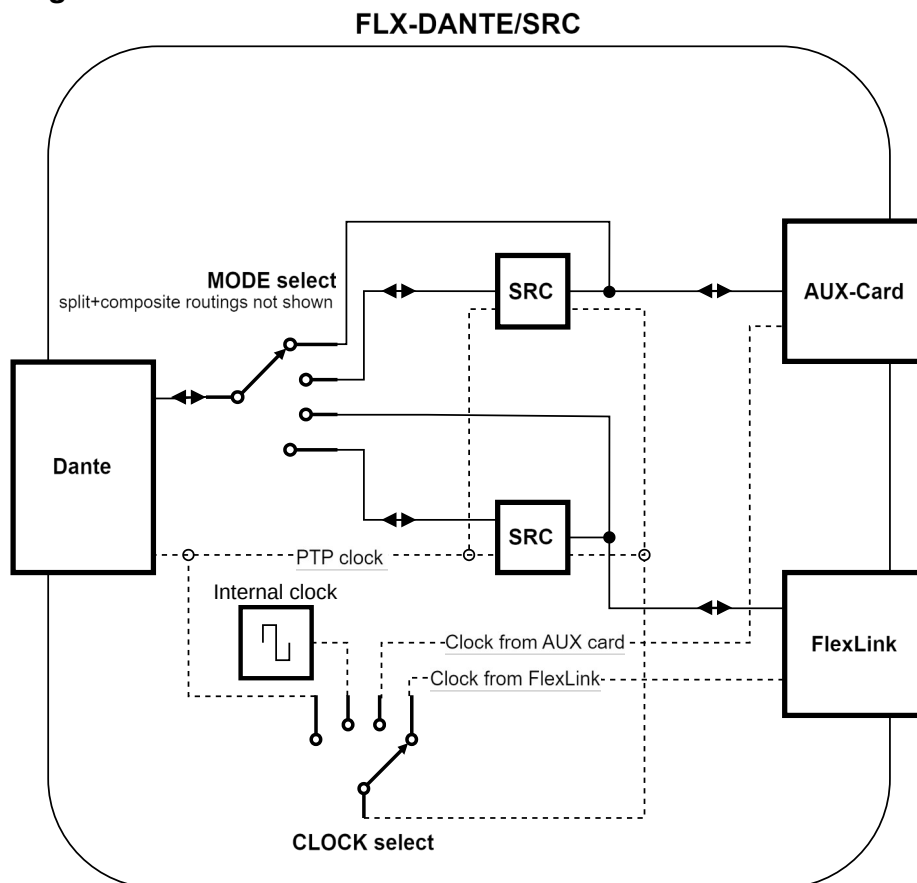

2.2. Block diagram



2.3. Box Contents

- 1 FLX-DANTE/SRC Converter
- 1 HDMI cable 0.5m / 1.7 ft with locking screws
- 1 Power supply
- 1 Power cord (country specific)
- This manual

2.4. Conventions used in this manual

- A button on the front is shown like this:  **Mode** or  **Clock**
- A LED is shown like this:  off /  on /  blinking





Filled circles with an exclamation mark indicates an action that must be performed ("Required").





A section marked with an "information" icon indicates a useful tip.

3. TYPICAL SETUPS

The setups below show typical examples how the FLX-DANTE/SRC can be used. Please note that **many more combinations are possible**, i.e. connection to the MVR-mkll multiverter for channel-wise routing etc. Please don't hesitate to contact us at info@appsys.ch with your requirements.

	DANTE/DANTE bridge (compact)	DANTE/DANTE bridge (more channels)
Capacity per direction	64ch @ 48k 32ch @ 96k 16ch @ 192k	64ch @ 48k 64ch @ 96k 32ch @ 192k
Required devices	FLX-DANTE/SRC + AUX-DANTE 	FLX-DANTE/SRC (48k side) FLX-DANTE+AUX-DANTE (96k side) connected via FlexLink 
Device settings	MODE: Dante via SRC <> AUX CLOCK: AUX	48k side: MODE: Dante via SRC <> FlexLink CLOCK: FlexLink 96k side: MODE: Dante+AUX <> FlexLink CLOCK: Dante or Internal

	DANTE/MADI bridge	DANTE/AES50 bridge
Capacity per direction	Dante side MADI side 64ch @ 48k 64ch @ 48k 32ch @ 96k 64ch @ 96k 16ch @ 192k 32ch @ 192k	Dante side AES50 side 64ch @ 48k 96ch @ 48k 32ch @ 96k 48ch @ 96k 16ch @ 192k
Required devices	FLX-DANTE/SRC+AUX-MADI*(-DUAL) 	FLX-DANTE/SRC FLX-AES50 connected via FlexLink 
Device settings	MODE: Dante via SRC <> AUX CLOCK: AUX	FLX-DANTE/SRC MODE: Dante via SRC <> FlexLink CLOCK: FlexLink FLX-AES50: MODE: AES50 A+B <> FlexLink CLOCK: AES50 or Internal

3.1. Available AUX cards

Lorem ipsum

At the time of writing (2025-01), the following AUX cards are available. More will come, please check www.appsys.ch for updates.

Item	Description
AUX-ADAT	16x16ch ADAT I/O (2x In+2x out). Supports also S/PDIF
AUX-ADAT-64	64x64ch ADAT I/O (8x In+8x out). Connectors on breakout box
AUX-AES3	8x8ch AES3 I/O on 1x DB25, fully transformer isolated
AUX-DANTE	64x64ch DANTE network card
AUX-MADI-COAX	64x64ch MADI for coaxial cable (2xBNC connectors)
AUX-MADI-COAX-DUAL	64x64ch @ 96k MADI for coaxial cable (4x BNC connectors)
AUX-MADI-OPTO	64x64ch MADI optical, SC connector (Multimode 125um 1310 nm)
AUX-MADI-SFP	64x64ch MADI for SFP (Small-Factor Pluggable) modules
AUX-MADI-SFP-DUAL	64x64ch @ 96k MADI for SFP (Small-Factor Pluggable) modules
AUX-MADI-TP	64x64ch Twisted-Pair (Cat5) MADI I/O for DiGiCo/Soundcraft/Studer
AUX-MADI-TP-DUAL	64x64ch @ 96k Dual Twisted-Pair (Cat5) MADI I/O for DiGiCo/Soundcraft/Studer
AUX-TDM	32x32 channel TAM (Time Division Multiplexing/I2S), 3.3V LVCMOS I/O, ribbon cable connector
AUX-WORDCLOCK	BNC wordclock I/O

3.2. Available FLX devices

At the time of writing (2025-01), the following FLX devices are available. More will come, please check www.appsys.ch for updates.

Item	Description
FLX-AES3	16x16 channel AES3 flexiverter (with AUX slot)
FLX-AES3/SRC	16x16 channel AES3 flexiverter with individual SRCs on the AES3 inputs
FLX-AES50	96x96 channel AES50 flexiverter (with AUX slot)
FLX-DANTE	64x64 channel DANTE flexiverter (with AUX slot)
FLX-DANTE/SRC	64x64 channel DANTE flexiverter with bi-directional 64x64ch SRC
FLX-MADI	128x128 channel MADI SFP & MADI coaxial module (with AUX slot)

3.3. FlexLink connection



The FlexLink connection is designed to connect Flexinverters with each other, or with the Multiverter. It provides:

- 192x192 channels (at 48kHz) bi-directional transmission of 24-bit uncompressed audio (fully transparent to AES3 compatible metadata bits)
- Super-low link latency of 4 samples (ca. 83µs)
- Dedicated, high-quality reference clock signal with automatic configuration
- Power supply for connected devices (to reduce cabling), alternatively serves as redundancy scheme when both devices are powered: in case of power failure, both devices keep working from the remaining power supply.
- Uses standard HDMI cables (with locking screws), to provide easy field replacement in case of defects.

4. AUDIO ROUTING

The flexiverter can operate in various routing modes, allowing you to pass audio between the available interfaces in many different ways. The LEDs in the "MODE" section indicate the involved interfaces.

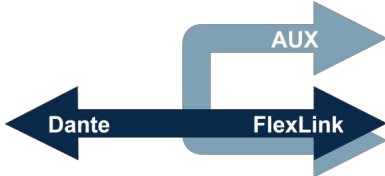
4.1. Modes and indication

► Non-SRC (direct) modes				
#	Mode (route between)	Operation (Example)	Setup (blinking alternately, meaning "from goes to")	Remarks
#1	Dante Direct(+AUX) ⇔ FlexLink 	<ul style="list-style-type: none"> ● Dante Direct ○ Dante via SRC ● AUX ● FlexLink 	<ul style="list-style-type: none"> * ○ Dante Direct ○ ○ Dante via SRC * ○ AUX ○ * FlexLink 	<ul style="list-style-type: none"> ■ AUX LED only active when card installed
#2	Dante Direct ⇔ AUX 	<ul style="list-style-type: none"> ● Dante Direct ○ Dante via SRC ● AUX ○ FlexLink 	<ul style="list-style-type: none"> * ○ Dante Direct ○ ○ Dante via SRC * ○ AUX ○ ○ FlexLink 	<ul style="list-style-type: none"> ■ Only available with AUX installed. ■ Channel offset in AUX can be changed¹ ■ Additional split of everything to FlexLink²
#6 ³	Dante Direct ⇔ 32ch AUX+32ch FlexLink 	<ul style="list-style-type: none"> ● Dante Direct ○ Dante via SRC ● AUX ● FlexLink 	<ul style="list-style-type: none"> * ○ Dante Direct ○ ○ Dante via SRC * ○ AUX * ○ FlexLink 	<ul style="list-style-type: none"> ■ Half/Half mode: The lower half of the channels to/from AUX, the upper half to/from FlexLink⁴. From FW 2.9 on. ■ Only available with AUX installed. ■ Channel offset in AUX can be changed¹

1 The channel block where the data is inserted/extracted into the AUX stream can be changed (available from firmware 2.9 on). See 8.3 AUX Card Channel Offset (DIP7..9)

2 All incoming data is also split (output) to FlexLink: AES3 A+B are split to Lane 1 (ch1-64), AUX is split to Lane 2 (ch65-128), The split is not indicated on the LEDs for clarity but is always active.

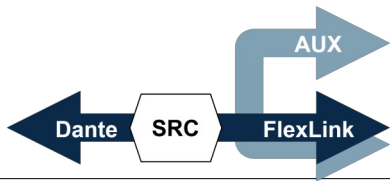
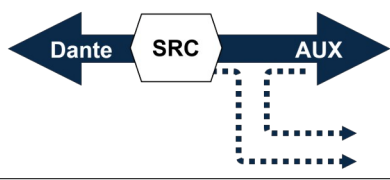
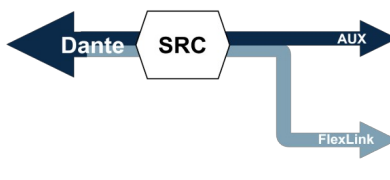

3 Mode #6 comes logically after #5 during the selection

4 The size of the blocks is determined by main system clock:
 32+32ch @48k, 16+16ch@96k, 8+8ch@192k. Depending on the Dante modules clock, not all channels might be available on Dante. Available from Firmware 2.9 on.

► SRC (Sample Rate Conversion) modes				
#	Mode (route between)	Operation (Example)	Setup (blinking alternately, meaning "from goes to")	Remarks
#3	Dante via SRC(+AUX) ⇔ FlexLink	 <ul style="list-style-type: none"> ○ Dante Direct ● Dante via SRC ● AUX ● FlexLink 	<ul style="list-style-type: none"> ○ Dante Direct * Dante via SRC * AUX ○ FlexLink 	<ul style="list-style-type: none"> ○ Dante Direct ○ Dante via SRC ○ AUX * FlexLink <ul style="list-style-type: none"> ■ AUX LED only active when card installed
#4	Dante via SRC ⇔ AUX	 <ul style="list-style-type: none"> ○ Dante Direct ● Dante via SRC ● AUX ○ FlexLink 	<ul style="list-style-type: none"> ○ Dante Direct * Dante via SRC ○ AUX ○ FlexLink 	<ul style="list-style-type: none"> ○ Dante Direct ○ Dante via SRC * AUX ○ FlexLink <ul style="list-style-type: none"> ■ Only available with AUX installed. ■ Channel offset in AUX can be changed¹ ■ Additional split of everything to FlexLink²
#5	Dante via SRC ⇔ 32ch AUX+32ch FlexLink	 <ul style="list-style-type: none"> ○ Dante Direct ● Dante via SRC ● AUX ● FlexLink 	<ul style="list-style-type: none"> ○ Dante Direct * Dante via SRC ○ AUX ○ FlexLink 	<ul style="list-style-type: none"> ○ Dante Direct ○ Dante via SRC * AUX * FlexLink <ul style="list-style-type: none"> ■ Half/Half mode: The lower half of the channels to/from AUX, the upper half to/from FlexLink⁴. From FW 2.9 on. ■ Only available with AUX installed. ■ Channel offset in AUX can be changed¹

LED color	Meaning
○ off	Interface not active / involved
● green	IN and OUT valid
● white	OUT valid, but no IN detected
● red	No valid signal or no valid clock. <ul style="list-style-type: none"> ◆ If the clock LEDs show red, make sure the clock mode is set correctly and a valid clock is supplied. ◆ If the clock LEDs show green, the clock is ok but the input is not detected. Check the respective connection.
* red blinking	Interface is currently booting and not yet active
* yellow blinking	Mode setting active: Alternately blinking LEDs indicate the interfaces between which data is converted; constant lit LEDs indicate splitting destinations. The blink phase alternates between source and sink. Press MODE button again to cycle through available modes. After 4 seconds, the selected mode is applied automatically.

4.2. Selecting the Route Mode



- Long-press the  button until the LEDs are blinking yellow. Current routing mode is shown by alternately yellow blinking LEDs, indicating the interfaces where the signal is passed between.
- Press the  button repeatedly to cycle between available modes, until the desired mode is shown.



- Observe which LEDs are blinking alternately. The first phase indicates signal "source", the other "sink". Think of it as **"The blink alternates between source and sink"**

- After four seconds without interaction, selection mode is terminated and the current setting comes into effect.

4.3. Remarks

- Routing between the selected interfaces is always bi-directional, meaning that audio is passed between them both ways. A working bi-directional link shows  green for both interfaces. If the LED shows  white, the corresponding interface does only output data but no input on it has been detected. If the LED shows  red, the interface is not connected, or the clock is invalid or missing.
- Channel-wise routing and splitting (crosspoint switch/matrix) between all channels is possible when the flexiverter is connected to a multiverter. Routing is then done via the multiverter's web interface or via the command line.

5. CLOCK SETTINGS

5.1. Clock sources and indication



When the SRC is active, the clock setting below **affects only the main clock** (used for AUX and FlexLink, after the SRC). The independent clock on the Dante side (before the SRC) must be set in the Dante controller.







The main clock can be taken from every interface (acting as clock slave), or can be generated internally (acting as clock master).

Clock source	"Clock" Indication (Example)	Remarks
Dante Direct	<ul style="list-style-type: none"> <input checked="" type="radio"/> Dante Direct <input type="radio"/> 44.1 kHz <input type="radio"/> INT <input checked="" type="radio"/> 48 kHz <input type="radio"/> AUX <input type="radio"/> x2 <input type="radio"/> FlexLink <input type="radio"/> x4 	Available as clock source only when SRC is disabled. Indication only for the Dante clock when SRC is enabled
Internal ("INT")	<ul style="list-style-type: none"> <input type="radio"/> Dante Direct <input type="radio"/> 44.1 kHz <input checked="" type="radio"/> INT <input checked="" type="radio"/> 48 kHz <input type="radio"/> AUX <input type="radio"/> x2 <input type="radio"/> FlexLink <input type="radio"/> x4 	Flexiverter acts as clock master for the main clock.
AUX	<ul style="list-style-type: none"> <input type="radio"/> Dante Direct <input type="radio"/> 44.1 kHz <input type="radio"/> INT <input checked="" type="radio"/> 48 kHz <input checked="" type="radio"/> AUX <input type="radio"/> x2 <input type="radio"/> FlexLink <input type="radio"/> x4 	Only available with AUX installed. AUX card is source for the main clock.
FlexLink	<ul style="list-style-type: none"> <input type="radio"/> Dante Direct <input type="radio"/> 44.1 kHz <input type="radio"/> INT <input checked="" type="radio"/> 48 kHz <input type="radio"/> AUX <input type="radio"/> x2 <input checked="" type="radio"/> FlexLink <input type="radio"/> x4 	Main clock is taken from the peer device (Flexiverter or Multiverter)

LED color	Meaning
<input type="radio"/> off	Interface not active / not involved
<input checked="" type="radio"/> green	Selected, locked and synced
<input checked="" type="radio"/> red	No valid clock. No input connected or no master clock signal detected
<input checked="" type="radio"/> yellow blinking	Clock setting active. Press CLOCK button to go to the next clock source. After 4 seconds, selection mode is terminated and the selected mode comes into effect.

5.2. Selecting the Main Clock Source

Only the configuration for the main clock (used for AUX and FlexLink) can be set here. The Dante clock configuration must be set in the Dante controller.

- Long-press the  button until the LEDs are blinking yellow
- Current clock source/modes is shown by blinking LED(s)
- Press the  button repeatedly to cycle between the available clock sources. Depending on the source, you might need to select the desired sample rate ( 44.1 kHz or  48 kHz) and/or the appropriate multipliers ( x2 /  x4)
- After four seconds without interaction, clock setting is automatically terminated and the selected clock source comes into effect



When the samplerate is incorrectly set (e.g. 48k with 96k data), unwanted effects (clicks, double samples, zero samples, channel crosstalk etc.) may occur and might not be noticed immediately. Always double-check that the samplerate is set correctly on all involved devices!

5.3. Display the clock status of both clocks

The status of the Dante clock (configured in the Dante controller) can be shown when desired:

- Short-press the  button to toggle between indication of the "Main" and the "Dante" clock.

6. REMOTE CONTROL

6.1. Browser-based control

This does not require any software to be installed. It works as hybrid app where the user interface is fetched from the web, and your browser talks to the device via USB connection.



Web control is currently only available in **Chrome, Edge and Opera** on Windows and Mac. Not supported on mobile devices and Safari/Firefox.

To use web control:

- Connect the device to your computer using an USB cable
- Open your browser and go to www.appsys.ch/remote
- When the browser requests access to the serial port, give permission on the first port listed

6.2. Command line control

A command line is available via the USB serial port. To use it, you need a terminal software (Hyper terminal, PuttY, minicom or similar) which can talk to a serial ("COM") port.

To use the command line:

- Connect the device to your computer using an USB cable
- Open the terminal software. Select the first COM port which appears when plugging in the device
- Select 115200 bps, 8N1 as communication parameters
- To see what you're typing, turn local echo "on" in the terminal software
- To see a list of available commands, type **he1p** at the **FLX>** command prompt

7. ACCESSING INTERNALS

7.1. Opening the device

- Required: Torx T10 screwdriver.
- Power off the device and detach all cables to avoid short-circuit or damage.
- Detach the device from the rack-mount kit.
- Remove the four top screws and the top cover by pulling it upwards:

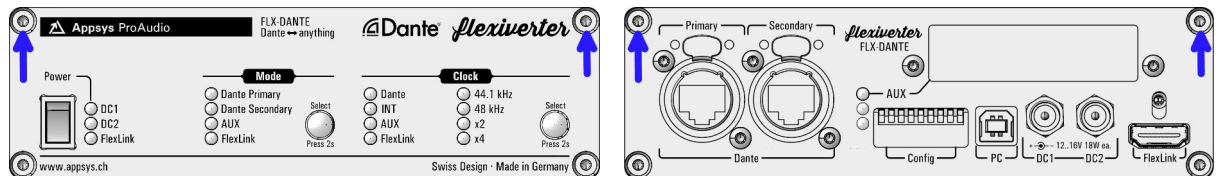

7.2. Inside view

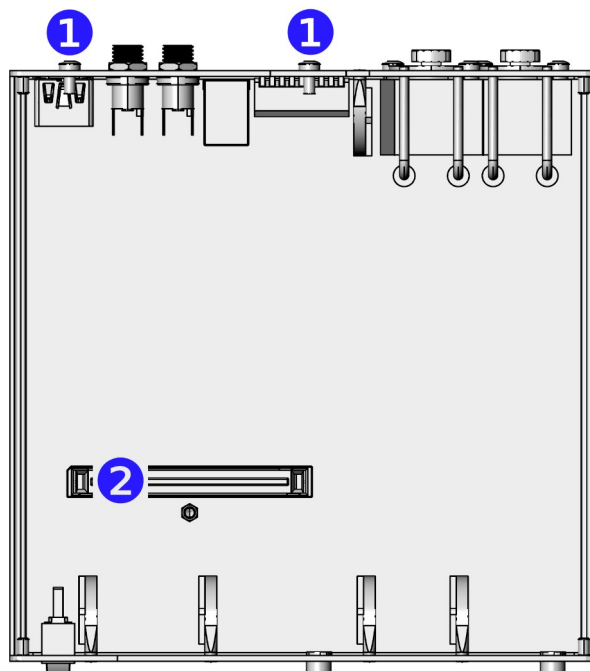

1	Screws for AUX cover plate
2	AUX card connector

7.3. Installing AUX cards

- Remove the screws holding the cover plate, and the blank cover plate **1**
- Insert the AUX card from inside, using the supplied cover plate. Make sure it is correctly fitted to the card connector **2**
- Secure the card using two cover screws **1**
- The card has been installed correctly if you are able to select an audio routing mode involving AUX (long-press MODE button to enter Route Mode Selection).

8. DIP SETTINGS

Fine-tuning of the flexiverter's built-in interface behavior and of the AUX card can be achieved via DIP settings on the back side. Changing the DIP settings will come immediately into effect. DIP switches 2 and 3 are reserved for future use.

Default setting: all switches up.

8.1. Base Device Config (DIP1)

<input type="checkbox"/> 1	Enable Dante auto configuration (external WCLK, samplerate) in non-SRC modes (In SRC modes, the Dante module configuration is always done from the Dante controller/Dante Domain Manager)
<input type="checkbox"/> 1	Disables Dante auto configuration (external WCLK, samplerate). Use this if you want to control behaviour by Dante Domain Manager

8.2. AUX Card Config (DIP4..6)

Many AUX card provide additional settings, which can be adjusted using these switches. The actual meaning depends on the type of AUX card installed:

AUX-ADAT	<input type="checkbox"/> 4	Channels 1-8: ADAT format* ⁵	<input type="checkbox"/> 5	Channels 9-16: ADAT format* ⁵	<input type="checkbox"/> 6	Clock source: Auto* ⁶	
	<input type="checkbox"/> 4	Channels 1-2: AES3/SPDIF fmt ⁵	<input type="checkbox"/> 5	Channels 9-10: AES3/SPDIF fmt ⁵	<input type="checkbox"/> 6	Clock source: Always input 1 ⁶	
AUX-ADAT-64	<input type="checkbox"/> 4	<input type="checkbox"/> 5	ADAT output on all connectors 1-8 *			<input type="checkbox"/> 6	Clock source: Auto* ⁶
	<input type="checkbox"/> 4	<input type="checkbox"/> 5	SPDIF/AES3 output on connector 1 ADAT output on connectors 2-8			<input type="checkbox"/> 6	Clock source: Always input 1 ⁶
	<input type="checkbox"/> 4	<input type="checkbox"/> 5	SPDIF/AES3 output on conn. 1-2 ADAT output on connectors 3-8				
	<input type="checkbox"/> 4	<input type="checkbox"/> 5	SPDIF/AES3 output on conn. 1-3 ADAT output on connectors 5-8				
AUX-AES3	<input type="checkbox"/> 4	<input type="checkbox"/> 5	Single Wire (full channel count at 48k, 96k and 192k), professional format for metadata*			<input type="checkbox"/> 6	Clock source: Auto* ⁶
	<input type="checkbox"/> 4	<input type="checkbox"/> 5	Double wire (half channel count), only in 96k and 192k modes			<input type="checkbox"/> 6	Clock source: Always input 1 ⁶

⁵ Applies to output only, input-format is always auto-detected

⁶ From FLX device firmware 3.0 on. Older firmware has always "AUTO"

	<input type="checkbox"/> 4 <input type="checkbox"/> 5	Quad wire (quarter channel count), only in 192k mode	
	<input type="checkbox"/> 4 <input type="checkbox"/> 5	Single wire, SPDIF (consumer) format for metadata	
AUX-DANTE	<input type="checkbox"/> 4	Enable AUX-DANTE card auto configuration (external WCLK yes/no, samplerate) depending on flexiverter settings	
	<input type="checkbox"/> 4	Disable AUX-DANTE card auto configuration Use this if you want to control behavior by Dante Domain Manager	
AUX-MADI-COAX AUX-MADI-OPTO AUX-MADI-SFP AUX-MADI-TP	<input type="checkbox"/> 4	96k frame* ⁵	<input type="checkbox"/> 5 <input type="checkbox"/> 6 64ch output* ⁵
	<input type="checkbox"/> 4	48k frame ⁵	<input type="checkbox"/> 5 <input type="checkbox"/> 6 57ch (use for DiGiCo stagebox control) ⁵
			<input type="checkbox"/> 5 <input type="checkbox"/> 6 56ch output ⁵
			<input type="checkbox"/> 5 <input type="checkbox"/> 6 reserved
AUX-TDM	<input type="checkbox"/> 4 <input type="checkbox"/> 5	*TDM16. Each I/O line carries 16 channels of 32 bit audio data each (512 bits/BCLK cycles per LRCLK)	
	<input type="checkbox"/> 4 <input type="checkbox"/> 5	TDM8. Each I/O line carries 8 channels of 32 bit audio data each (256 bits/BCLK cycles per LRCLK)	
	<input type="checkbox"/> 4 <input type="checkbox"/> 5	TDM4. Each I/O line carries 4 channels of 32 bit audio data each (128 bits/BCLK cycles per LRCLK)	
	<input type="checkbox"/> 4 <input type="checkbox"/> 5	TDM2 (Stereo). Each I/O line carries 2 channels of 32 bit audio data ea. (64 bits/BCLK cycles per LRCLK)	
	<input type="checkbox"/> 6	*Left-justified, 32 bit per ch (24 bit audio data + 8 bits zero padding)	
	<input type="checkbox"/> 6	I2S-Format, 32 bit per ch (24 bit audio data + 8 bits zero padding) Data is delayed by 1 BCLK cycle	
AUX-WORDCLOCK	<input type="checkbox"/> 4	True to samplerate* ⁵	
	<input type="checkbox"/> 4	Always x1 (single speed) ⁵	

* Default setting

























For cards not listed, refer to the manual of the respective card, or check for a newer version of this manual.

8.3. AUX Card Channel Offset (DIP7..9)⁷

For some configurations (i.e. multiple flexinverters with daisy-chained AUX-MADI cards), it may be desired to keep the incoming AUX data and insert/extract the converted data not at the beginning of the AUX stream, but on a different location. The location within AUX where the insertion/extraction of the converted data starts is called "offset" and can set below using DIP switches 7..9.



AUX channel offset via DIP7..9 is only available in modes where the AUX card is the primary conversion target. These modes are #2 and #4 (see p.11, Modes and indication). This feature is available from firmware 2.9 on.

DIP	Offset	Description
   7 8 9	0*	Audio data is copied from/to AUX starting from channel 0 (default)
   7 8 9	8	Audio data is copied from/to AUX starting at the specified offset (NOTE: numbers are halved at 96k, and quartered at 192k) The AUX input channels below this offset are directly passed through to the AUX , i.e. are copied from AUX input to AUX output. All channels exceeding the capacity of the AUX card are ignored.
   7 8 9	16	
   7 8 9	24	
   7 8 9	32	
   7 8 9	40	
   7 8 9	48	
   7 8 9	56	



















⁷ Available from firmware 2.9 on

8.4. FlexLink Channel Mapping (DIP7..9)

The FlexLink interface can transmit 192x192 channels, organized in three lanes with 64 channels each. The channel assignment can be adjusted to meet the user's needs, particularly when the device is used in double-FLX configuration (to make sure that all interfaces and channels are mapped to the desired target on the peer FLX device).





Lane assignment (DIP7..9) is only available in routing modes #1 and #3 where FlexLink is the primary conversion target. (From firmware 2.9 on)

DIP	Lane 1 (ch1-64)	Lane 2 (ch65-128)	Lane 3 (ch129-192)
   7 8 9	Dante*	AUX	-
   7 8 9	Dante	-	AUX
   7 8 9	AUX	Dante	-
   7 8 9	AUX	-	Dante
   7 8 9	-	Dante	AUX
   7 8 9	-	AUX	Dante

* Default setting

9. SPECIAL OPERATING MODES

Special operating modes are accessible by **holding down the  Mode button while switching on the device.** Press  Mode again to switch to the next mode:

Version Display ⇒ **LED Test** ⇒ **Interface Self-Test** ⇒ **Normal operation**

9.1. Version Display

The hardware and firmware version are indicated on the MODE and CLOCK LEDs. The values are binary encoded. To get the version number, add all numbers from the "value" column where the corresponding LED is lit. The example below shows: hardware version 1, firmware version 2.7:

Value	MODE	CLOCK	
	Hardware version: green LEDs	Major	Minor
8	○	○	○
4	○	○	●
2	○	●	●
1	●	○	●

- Blinking LEDs mean that the currently installed firmware is a "beta" version. It is advised to upgrade to an official release version as soon as it is released.
- Press again to proceed to LED test.

9.2. LED Test

- All LEDs on the front and on the back should show ● white.
- Press again to proceed to Interface Self-Test.

9.3. Interface Self-Test

All built-in interfaces and the optional AUX card can be tested for correct operation by the user. This is done using the special self-test mode, in which the device outputs a special random test pattern on all channels. This pattern is looped back via an external cable into the corresponding inputs, where it is checked for consistency.

- Self-test mode is indicated with "CLOCK" showing INT/48kHz in ● cyan color. The "MODE" LEDs indicate ● red (error/no connection) or ● green (loopback data received ok) for the respective interface.
- Connect the Dante Primary port to your network.

- Connect the Dante Secondary port to a separate switch. **Note: This switch should NOT have *any other* connection to your network, otherwise there is a chance that your LANs forwarding rules are messed up– it can take hours until everything works again!**
- If an AUX card is installed, connect all output ports of the AUX card to the respective inputs using a loop-back cable. Note: NOT supported with AUX-ADC, AUX-AES67, AUX-AVB, AUX-DANTE.

9.4. Firmware update

This is a two-step process:

1. Base **Device firmware** is updated through the **USB** port on the rear
2. **Dante firmware** is flashed on the built-in Dante module over the **network**



The firmware of the base device (updated over USB), and the firmware of the Dante module (updated over Ethernet) are mutually coordinated and must **BOTH** be updated.⁸

► Preparation

- Download the latest firmware from www.appsys.ch/FLX-DANTE
- Unpack the firmware package FLX-DANTE-Firmware_x.y.zip
- Connect your PC via USB to the flexiverter
- Connect one of the Dante ports to your local network
- Power ON the device

► Updating the base device (over USB)

- Run the **FLX-DANTE_Updater.bat** file from the firmware package and follow the instructions on the screen.
- Power cycle the device to effect the base device update

⁸ You don't need to update the Dante firmware if **FLX-DANTE_x.x.x.x.dnt** file from the previously installed version did not change in the current version.

► **Updating the Dante firmware (over Network)**

- Use [Dante Firmware Update Manager](#) (or Dante Updater built into Dante Controller) to flash the `firmware\FLX-DANTE_x.x.x.x.dnt` file contained in the firmware package onto the device.

10. SPECIFICATIONS

Parameter	Value																					
Dimensions	152x44x153mm (WxHxD) excluding connectors/buttons 152x44x163mm (WxHxD) including device-side connectors/buttons																					
Weight	620g																					
Operating temperature	0..+55°C, non-condensing																					
Storage temperature	-40..+85°C, non-condensing																					
Power consumption	+15V DC, 9W max (18W to power two devices via FlexLink) Triple-redundant input (2x DC, 1x via FlexLink)																					
Dante Network Ports	1000BASE-T (Gigabit), compatible to 100BASE-T Primary/Secondary ports configurable as "Switched" (default) or "Redundant"																					
Cable lengths	FlexLink	1m/3ft. max. recommended																				
	Network	100m/300 ft. Cat5 or better cable required for 1000BASE-T operation																				
Channel count	64x64 @ 48kHz 32x32 @ 96kHz 16x16 @ 192kHz plus additional AUX channels depending on AUX card																					
Sample rates	44.1kHz, 48kHz, 88.2kHz, 96kHz, 176.4kHz, 192kHz																					
SRC performance	THD+N: -133 dB typ. / -120dB max. Dynamic range (A-weighted, 20 Hz to 20 kHz): 139 dB																					
SRC latency	<p>When using the Sample Rate Converter (SRC), there is ~0.5ms...1ms latency added. The table below contains the exact values.</p> <table border="1"> <thead> <tr> <th colspan="2">For up-sampling conversions: $t/s = 16/fs_in + 32/fs_in$</th> </tr> <tr> <th>fs_in / kHz</th> <th>t / ms</th> </tr> </thead> <tbody> <tr> <td>32</td> <td>1.5</td> </tr> <tr> <td>44.1</td> <td>1.09</td> </tr> <tr> <td>48</td> <td>1.03</td> </tr> <tr> <td>64</td> <td>0.75</td> </tr> <tr> <td>88.2</td> <td>0.54</td> </tr> <tr> <td>96</td> <td>0.5</td> </tr> <tr> <td>128</td> <td>0.375</td> </tr> <tr> <td>176.2</td> <td>0.27</td> </tr> </tbody> </table>		For up-sampling conversions: $t/s = 16/fs_in + 32/fs_in$		fs_in / kHz	t / ms	32	1.5	44.1	1.09	48	1.03	64	0.75	88.2	0.54	96	0.5	128	0.375	176.2	0.27
For up-sampling conversions: $t/s = 16/fs_in + 32/fs_in$																						
fs_in / kHz	t / ms																					
32	1.5																					
44.1	1.09																					
48	1.03																					
64	0.75																					
88.2	0.54																					
96	0.5																					
128	0.375																					
176.2	0.27																					

Parameter	Value																																																	
	<p>For down-sampling conversions: $t/s = 16/fs_in + (32/fs_in)*(fs_in/fs_out)$</p> <table border="1"> <thead> <tr> <th>fs_in / kHz</th> <th>fs_out / kHz</th> <th>t / ms</th> <th>fs_in / kHz</th> <th>fs_out / kHz</th> <th>t / ms</th> </tr> </thead> <tbody> <tr> <td>48</td> <td>44.1</td> <td>1.06</td> <td rowspan="3">176.4</td> <td>44.1</td> <td>0.82</td> </tr> <tr> <td rowspan="2">88.2</td> <td>44.1</td> <td>0.91</td> <td>48</td> <td>0.76</td> </tr> <tr> <td>48</td> <td>0.84</td> <td>88.2</td> <td>0.45</td> </tr> <tr> <td rowspan="3">96</td> <td>44.1</td> <td>0.89</td> <td>96</td> <td>0.42</td> </tr> <tr> <td>48</td> <td>0.83</td> <td rowspan="3">192</td> <td>44.1</td> <td>0.81</td> </tr> <tr> <td rowspan="2">88.2</td> <td rowspan="2">0.53</td> <td>48</td> <td>0.75</td> </tr> <tr> <td>88.2</td> <td>0.45</td> </tr> <tr> <td></td> <td></td> <td></td> <td></td> <td>96</td> <td>0.42</td> </tr> <tr> <td></td> <td></td> <td></td> <td></td> <td>176.4</td> <td>0.26</td> </tr> </tbody> </table>	fs_in / kHz	fs_out / kHz	t / ms	fs_in / kHz	fs_out / kHz	t / ms	48	44.1	1.06	176.4	44.1	0.82	88.2	44.1	0.91	48	0.76	48	0.84	88.2	0.45	96	44.1	0.89	96	0.42	48	0.83	192	44.1	0.81	88.2	0.53	48	0.75	88.2	0.45					96	0.42					176.4	0.26
fs_in / kHz	fs_out / kHz	t / ms	fs_in / kHz	fs_out / kHz	t / ms																																													
48	44.1	1.06	176.4	44.1	0.82																																													
88.2	44.1	0.91		48	0.76																																													
	48	0.84		88.2	0.45																																													
96	44.1	0.89	96	0.42																																														
	48	0.83	192	44.1	0.81																																													
	88.2	0.53		48	0.75																																													
88.2				0.45																																														
				96	0.42																																													
				176.4	0.26																																													
Internal clock precision	Jitter: Phase RMS: <1ps, Peak-peak: <50ps. Stability: ±25 ppm including all effects including aging, temperature, supply, calibration, shock, vibration																																																	

11. ACCESSORIES

11.1. Rack mount kits

For integration in 19" racks, two kinds of rack mount kits / brackets are available:

- **RM-FLX1:** For mounting one FLX device into 1U 19" space
- **RM-FLX2:** For mounting two FLX devices into 1U 19" space

11.2. Additional (redundant) power supply

- **PWR-FLX:** Additional power supply to provide redundancy for single-FLX configurations
- **FlexLink Cable 0.5m.** HDMI cable with locking screws

12. APPENDIX

12.1. Warranty

We offer a full two (2) year warranty from the date of purchase. Within this period, we repair or exchange your device free of charge in case of any defect*. If you experience any problems, please contact us first. We try hard to solve your problem as soon as possible, even after the warranty period.

* Not covered by the warranty are any damages resulting out of improper use, willful damage, normal wear-out (especially of the connectors) or connection with incompatible devices.

12.2. Manufacturer contact

Appsys ProAudio
Rolf Eichenseher
Bullingerstr. 63 / BK241
CH-8004 Zürich
Switzerland

www.appsys.ch
info@appsys.ch
Phone: +41 43 537 28 51
Mobile: +41 76 747 07 42

12.3. FCC Compliance

This equipment has been tested and found to comply with the limits for a class B digital device, pursuant to part 15 of the FCC Rules. These limits are designed to provide reasonable protection against harmful interference in a residential installation. This equipment generates, uses and can radiate radio frequency energy and if not installed and used in accordance with the instructions, may cause harmful interference to radio communications. However, there is no guarantee that interference will not occur in a particular installation. If this equipment does cause harmful interference to radio or television reception, which can be determined by turning the equipment off and on, the user is encouraged to try to correct the interference by one or more of the following measures:

- Reorient or relocate the receiving antenna
- Increase the separation between the equipment and receiver
- Connect the equipment into an outlet on a circuit different from that to which the receiver is connected
- Consult the dealer or an experienced radio/TV technician for help

This equipment has been verified to comply with the limits for a class B computing device, pursuant to FCC Rules. In order to maintain compliance with FCC regulations, shielded cables must be used with this equipment. Operation with non-approved equipment or unshielded cables is likely to result in interference to radio and TV reception. The user is cautioned that changes and modifications made to the equipment without the approval of manufacturer could void the user's authority to operate this equipment.

12.4. Recycling



According to EU directive 2002/96/EU, electronic devices with a crossed-out dustbin may not be disposed into normal domestic waste. Please return the products back for environment-friendly recycling, we'll refund you the shipping fees.

12.5. About this document

All trademarks mentioned in this document are property of the respective owners. All information provided here is subject to change without prior notice.

Document Revision: 3 · 2026-02-26

Rev 3: Added routing scheme arrows, clarified DIP switch graphics

Rev 2: Added settings for firmware 2.9/3.0

Rev 1: Initial release

Copyright © 2021-2026 Appsys ProAudio · Printed in Germany

IDENT 9.00.17429.00

Declaration of Conformity

The manufacturer:

**Appsys ProAudio
Rolf Eichenseher
Bullingerstr. 63 BK 241
CH-8004 Zürich
Switzerland**

declares under sole responsibility that the products mentioned below:

Flexiverter FLX-DANTE/SRC

meet the requirements of the following standards:

**EN 55024:2010
EN 55032:2015 Class B
EN 61000-3-2:2006/A1/A2:2009
EN 61000-3-3:2009
EN 61000-6-3:2007/A1:2011**

Therefore the product fulfills the demand of the following EC directives:

73/23/EWG

(Directive related to electrical equipment designed for use within certain voltage limits)

89/336/EWG

(Directive related to electromagnetic compatibility)

The devices are marked accordingly.

Zürich, 21.11.2024



Rolf Eichenseher (CEO)