



Multiverter
Digital Format Converter
MVR-64

User's Manual

(en)

Table of Contents

1. GENERAL.....	4
1.1. Conventions used in this manual.....	4
1.2. Safety precautions.....	5
1.3. Foreword.....	5
1.4. Box Contents.....	5
2. INTRODUCTION.....	6
2.1. Front panel.....	6
2.2. Rear panel.....	6
2.3. Overview.....	7
2.4. User interface.....	7
3. CONNECTIONS OVERVIEW.....	12
3.1. AC Power.....	12
3.2. DC Power.....	12
3.3. ADAT/SPDIF/AES3 optical.....	12
3.4. PC/USB.....	13
3.5. RS485.....	13
3.6. Extension.....	14
3.7. MADI optical.....	14
3.8. MADI BNC.....	15
3.9. MADI TP.....	15
3.10. AES50.....	15
3.11. Wordclock.....	16
3.12. Dante/AES67.....	16
3.13. MIDI.....	17
3.14. Control data forwarding.....	17
4. PRESETS.....	19
4.1. Preset Recall.....	19
4.2. Preset Store.....	20
4.3. Changed presets.....	20
4.4. Auto-Store.....	21
5. ROUTING.....	22
6. CLOCKING.....	26
6.1. ClockShield.....	26
6.2. Clock source selection.....	27
6.3. Dante Clock.....	29
7. PANEL LOCK.....	30
8. MONITOR.....	31
9. ADVANCED TOPICS.....	33
9.1. Test tone mode.....	33
9.2. Configuration settings.....	33

Declaration of Conformity

The manufacturer:

Appsys ProAudio
Rolf Eichenseher
Bullingerstr. 63 BK 241
CH-8004 Zürich
Switzerland

declares under sole responsibility that the products mentioned below:

Multiverter MVR-64

meet the requirements of the following standards:

EN 55024:2010
EN 55032:2015 Class B
EN 61000-3-2:2006/A1/A2:2009
EN 61000-3-3:2009
EN 61000-6-3:2007/A1:2011

Therefore the product fulfills the demand of the following EC directives:

73/23/EWG

(Directive related to electrical equipment designed for use within certain voltage limits)

89/336/EWG

(Directive related to electromagnetic compatibility)

The devices are marked accordingly.





Zürich, 05.05.2016

Rolf Eichenseher (CEO)

9.3. Audio Interface self-test.....	37
9.4. LED and button test.....	38
9.5. ASRC self-test.....	39
10. FIRMWARE.....	40
10.1. Version check.....	40
10.2. Upgrade.....	41
11. COMMAND LINE REFERENCE.....	42
12. SPECIFICATIONS.....	43
13. ACCESSORIES.....	45
13.1. AES50/MADI-TP Pin swap adapter cable.....	45
13.2. MTA-64 Adapter for MADI-TP.....	45
13.3. SRC-64 Asynchronous Samplerate Converter Module (optional hardware).....	46
13.4. Break-out boxes.....	47
14. APPENDIX.....	48
14.1. Warranty.....	48
14.2. Manufacturer contact.....	48
14.3. FCC Compliance.....	48
14.4. Recycling.....	49
14.5. About this document.....	49

1. GENERAL

1.1. Conventions used in this manual

- A button on the front of the device is shown like this:  **Set**
- A particular LED on the front of the device is shown like this:  **WCLK**
- Text indicated on the seven-segment display is shown as  **02**
- Operations in a particular control method are indicated by a triangle: 
- **Front panel, Web or Command line**

A section marked with a warning sign mark tells you that the information is particularly important to avoid damage or malfunction.



Filled circles with an exclamation mark indicates an action that must be performed ("Required")



A section marked with a prohibited sign tells you that the action indicated is prohibited ("Prohibited")



A section marked with a "information" icon indicates a useful tip.



made to the equipment without the approval of manufacturer could void the user's authority to operate this equipment.

14.4. Recycling



According to EU directive 2002/96/EU, electronic devices with a crossed-out dustbin may not be disposed into normal domestic waste. Please return the products back for environment-friendly recycling, we'll refund you the shipping fees.

14.5. About this document

Rev.	Changes
10	Added safety precautions
9	Clarified Dante web control
9	Added Web control on different network
8	Adapted to firmware 4.0
8	Added FCC compliance statement
7	Improved formatting
6	Added Web and command line remote control
6	Adapted to firmware 3.1
6	Removed legacy descriptions
5	Revised AES50<=>MADI-TP adapter cable colors
5	Updated SRC-64 reference
5	Updated Dante settings
5	Various clarifications
4	Added description of firmware 1.4
4	Updated Manufacturer contact (land line phone number)
3	Added description of firmware 1.3 features
2	Corrected latency table
1	Initial release

All trademarks mentioned in this document are property of the respective owners. All information provided here is subject to change without prior notice.

Document Revision: 10 · 2020-02-21

Referenced firmware version: 4.1

Copyright © 2016-2019 Appsys ProAudio · Printed in Switzerland

14. APPENDIX

14.1. Warranty

We offer a full two (2) year warranty from the date of purchase. Within this period, we repair or exchange your device free o/f charge in case of any defect*. If you experience any problems, please contact us first. We try hard to solve your problem as soon as possible, even after the warranty period.

* Not covered by the warranty are any damages resulting out of improper use, willful damage, normal wear-out (especially of the connectors) or connection with incompatible devices.

14.2. Manufacturer contact

Appsys ProAudio
Rolf Eichenseher
Bullingerstr. 63 / BK241
CH-8004 Zürich
Switzerland

www.appsys.ch
info@appsys.ch
Phone: +41 43 537 28 51
Mobile: +41 76 747 07 42

14.3. FCC Compliance

This equipment has been tested and found to comply with the limits for a class B digital device, pursuant to part 15 of the FCC Rules. These limits are designed to provide reasonable protection against harmful interference in a residential installation. This equipment generates, uses and can radiate radio frequency energy and if not installed and used in accordance with the instructions, may cause harmful interference to radio communications. However, there is no guarantee that interference will not occur in a particular installation. If this equipment does cause harmful interference to radio or television reception, which can be determined by turning the equipment off and on, the user is encouraged to try to correct the interference by one or more of the following measures:

- Reorient or relocate the receiving antenna
- Increase the separation between the equipment and receiver
- Connect the equipment into an outlet on a circuit different from that to which the receiver is connected
- Consult the dealer or an experienced radio/TV technician for help

This equipment has been verified to comply with the limits for a class B computing device, pursuant to FCC Rules. In order to maintain compliance with FCC regulations, shielded cables must be used with this equipment. Operation with non-approved equipment or unshielded cables is likely to result in interference to radio and TV reception. The user is cautioned that changes and modifications

1.2. Safety precautions



This device is intended to be used in a professional environment with restricted access only.

1.3. Foreword

Thank you for purchasing one of the most innovative digital audio converters on the market. The multiverter was designed with true vendor independence and interoperability in mind, with the idea to make all your gear interact seamlessly.

Please note that due to the complex nature of such a product we decided to introduce functionality step-by-step, so you will find some functions described in this manual marked "available as firmware update". We will continue to supply firmware updates to continuously improve the functionality of the device.

Please don't hesitate to tell us your feedback, thoughts and ideas, we try hard to make the multiverter your most valuable tool!

1.4. Box Contents

- MVR-64 multiverter device
- AC power cord (country specific)
- This manual

2. INTRODUCTION

2.1. Front panel

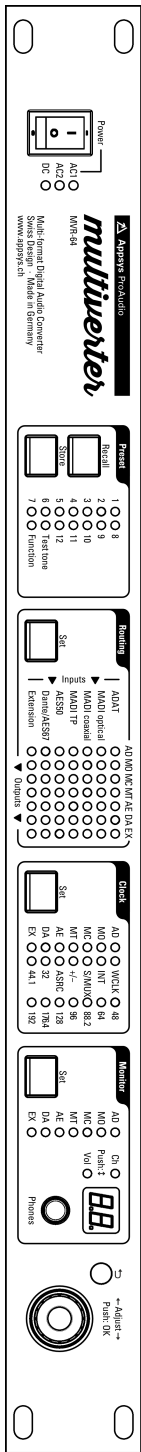

2.2. Rear panel

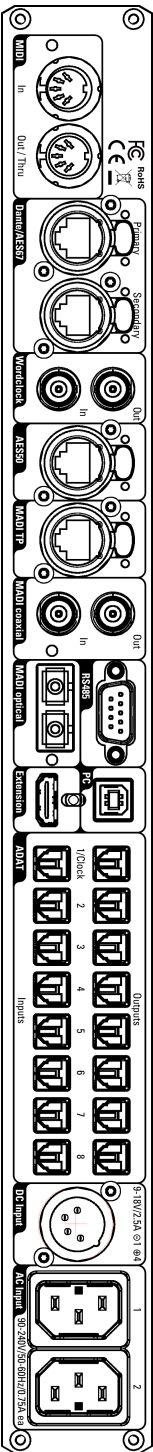

13.4. Break-out boxes

Various break-out boxes for connection to the "Extension" port will be available in the future. These boxes are designed to add support for non-built-in interfaces (e.g. AVB or Waves Soundgrid), and to add additional ports (e.g. MADI) to the system.

13.3. SRC-64 Asynchronous Samplerate Converter Module (optional hardware)

The [SRC-64](#) add-on module - available as separate hardware - adds the capability of asynchronous sample rate conversion to your multiverter. Designed as internal add-on module, it leaves the "Extension" port available to other break-out boxes. (Note: The module is called "ASRC" in this manual for clarity). It features highest analog performance (THD+N -134dB typ.) , 64-channel, bi-directional conversion between any interfaces supported by the multiverter plus a number of special modes for maximum flexibility. The ASRC can be

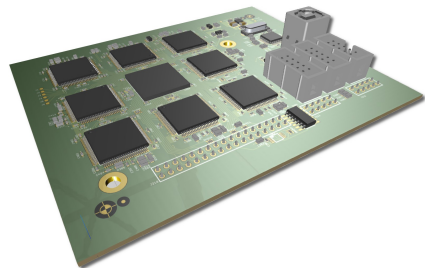

assigned to any input interface and also any output of the multiverter, giving a true bi-directional conversion between both clock domains:

- The ASRC is inserted (by software) between the selected input and the rest of the multiverter. The input can run independently, and the ASRC takes care of matching the data to the main clock of the multiverter.
- For the output, the ASRC can be inserted between the main clock of the multiverter and the selected output. The data is then converted to match the ASRC's asynchronous clock ("async clock") and sample rate before it is sent out.
- Existing multiverter routing capabilities are fully preserved.
- Special modes allow the use of two MADI or AES50 ports together, to send and receive all 64 channels at 96 kHz (48ch for AES50). Conversions between MADI 64ch@96k => MADI 64ch@48k or vice versa - using two MADI ports for the 96k part and one for the 48k part - are also supported.

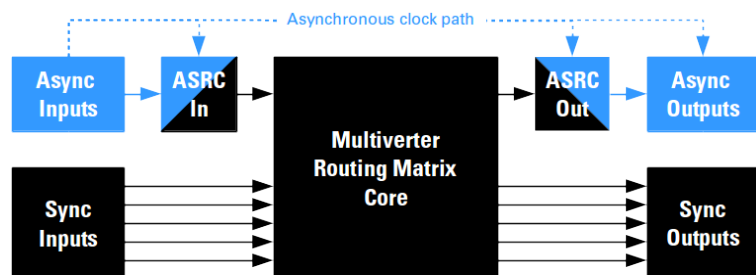

- Asynchronous clock domain („Async clock“).
Clock can be taken from async input, or BNC, or generated internally.
- Main clock domain.
Clock is taken from selected multiverter clock source

2.3. Overview

The multiverter is a unique device which allows you to convert digital audio data in any direction between the most popular formats: **ADAT, MADI optical, MADI coaxial, MADI-TP, AES50, Dante and others** (via break-out boxes).

All inputs can freely be routed to all of the outputs, with an arbitrary number of splits and merges supported at the same time.

Channel-wise routing between different interfaces is supported via the **remote control via integrated web server**, or via command line.

The routing matrix supports **448x448 channels** (7x7 interfaces with 64ch each) at single speed modes, 224x224 channels at double-speed and 112x112 channels at quad-speed modes.

Using the optional SRC-64 Asynchronous Samplerate Converter Module (optional hardware), **asynchronous sample rate conversion** on 64x64 bi-directional channels, up to 192kHz is supported.

The device is prepared for headamp remote control (Yamaha, Behringer, MIDAS)*.

Diagnostics are made simple by an integrated headphones amplifier and a test tone generator. Three power inlets allow operation from either AC or DC (battery pack) with full redundancy.

2.4. User interface

The device has been designed for fast and simple operation, with a no-frills everything-at-a glance concept. The unit can be operated either

- ▶ **directly on the front panel**
- ▶ **via the integrated web server**
- ▶ **via command line** (telnet or USB)
- ▶ **via MIDI** (Preset recall only)

In this manual, the required steps for each operation mode are indicated by ▶ **Front panel**, ▶ **Web** and ▶ **Command line** headers.

All operation modes can be used simultaneously, and any status change is immediately reflected on all interfaces. For example, it's possible to make some routing connections on the front panel, and later change them via the web interface or the command line.

* Not supported in firmware 4.1. Functionality will be supplied later via firmware update

▶ **Front panel**

Most settings are directly accessible without the need to walk through lengthy menus:

- To change a setting, first push the appropriate rectangular button (e.g. **Set**).
- You have now entered "Menu" mode, indicated by a yellow blinking cursor. Move the cursor by turning the encoder (rotary knob) left or right to move it to the desired setting.
- When the cursor is at the beginning or end of the column or line, continue turning to make it wrap around.
- Push the encoder knob (or push the appropriate menu button again) to confirm your changes. To return to the previous state without making any changes, push the **Back** button.
- When the device is normal operation (i.e. not within a menu), turning the encoder knob changes "Volume" or "Channel" of the monitor headphones, while pushing the encoder toggles between "Volume" and "Channel" mode.
- Channel-wise routing is *not* available from the front panel due to the lack of controls.

Thanks to the integrated web server, the multiviewer can be remotely operated from any browser. This is completely self-contained, platform independent and does not need any additional software.

▶ **Web**

Web control is the preferred method because it offers channel-wise routing and provides the most convenient graphical interface.



The web server runs on the Dante module, and can be configured to run.

(A) on the same network as the Dante audio. This is the normal configuration and allows to use Dante Audio redundancy.

(B) on a separate network, isolated from the Dante audio. In this case, the "Primary" port is used for audio, while "Secondary" port is used for remote control.

13. ACCESSORIES

13.1. AES50/MADI-TP Pin swap adapter cable

The AES50 and MADI-TP ports have different pin-outs as required by the respective standards. AES50 uses Pins 1/2 and 3/6 for the signal, 4/5 and 7/8 for sync, while a MADI-TP port uses 4/5 and 7/8 for the signal (with pins 1/2 and 3/6 reserved – this is where the AES50 sync signal is connected to in the multiviewer). To use the alternate function of such a port, an adapter cable with the pinout shown below is required:

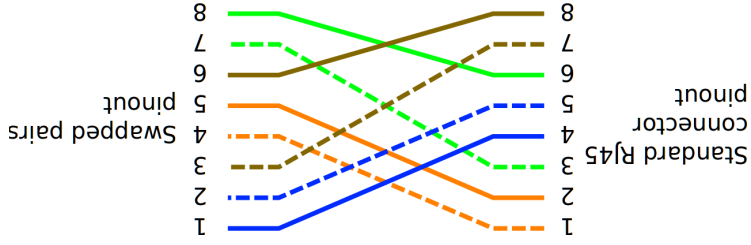

Illustration 1: AES50/MADI-TP swap cable

13.2.

MTA-64 Adapter for MADI-TP

With the **MTA-64**, the becomes capable of connecting to the MADI-TP (MADI over Twisted Pair) variants used in DiGiCo and Soundcraft/Studer/Harman desks. It's connected between the MVR-64's MADI-TP port and the console or stagebox and adapts signal levels and pin-outs. What's more: you don't need any special crossover cables thanks to internal MDIX logic - any standard 1:1 Cat5 cable will do, no matter if you want to connect to your console or the stagebox.



Parameter	Value
PC port	USB 2.0 (FTDI 2232). Remote control and firmware update, no audio connection
RS485 port	Male D-Sub 9pin, Yamaha AD8HR compatible Pinout: 2=RX-, 3=TX-, 4=TX+, 5=GND, 6=RX+
Extension port	HDMI connector type (not HDMI compatible). 64ch@32/44.1/48kHz, 32ch@64/88.2/96kHz, 16ch@128/176.4/192kHz
MADI optical port	SC connector, 50/125 µm or 62.5/125 µm multi-mode fiber (MM fiber), 1300nm, up to 2km total length. Transceiver can be changed to Single mode (9/125µm) at the factory on request. 64ch@32/44.1/48kHz, 32ch@64/88.2/96kHz, 16ch@128/176.4/192kHz 56/57/64 channel support, all AES3 bits (U, C, V) preserved
MADI BNC port	Standard AES10 coaxial port. Use with up to 100meters of 75 ohm coaxial cable 64ch@32/44.1/48kHz, 32ch@64/88.2/96kHz, 16ch@128/176.4/192kHz 56/57/64 channel support, all AES3 bits (U, C, V) preserved
MADI TP port	AES-X 213 (upcoming MADI specification) compatible. 64ch@32/44.1kHz, 56ch@48kHz, 32ch@64/88.2, 28ch@96kHz, 16ch@128/176.4kHz, 14ch@192kHz Pinout: MADI-TP on 4/5, 7/8 Alternative use: Second AES50 port, Pinout: Data on 4/5, 7/8; Sync on 1/2, 3/6 (adapter cable required) 56/57/64 channel support, all AES3 bits (U, C, V) preserved
AES50 port	AES50 3.1 compatible 48ch@44.1/48kHz, 24ch@88.2/96kHz Pinout: Data on 1/2, 3/6; Sync on 4/5, 7/8 Alternative use: Second MADI-TP with Pinout: 1/2, 3/6 (adapter cable required)
Wordclock port	Output: 5.0Vpp nominal, able to drive two parallel 75 Ohm terminations Input: 2.0Vpp...5.0Vpp
Dante/AES67 port	2x Gigabit Ethernet, configurable either as "Switch" or as "Redundant connection" in the Dante controller. Device prefix: "MVR64" 64ch@32/44.1/48kHz, 32ch@64/88.2/96kHz, 16ch@128/176.4/192kHz
MIDI port	Standard isolated input, standard MIDI output Data received on IN is passed unaltered to THRU
Headphones	2x125mW into 32Ohm (@0.01% THD+N) Bandwidth: 22Hz to 22kHz
ESD protection	all ports: +/- 15kV (Human Body Model)

Table 6: Specifications

(A) Remote control on the audio network

To access the web control, figure out the symbolic name (as displayed in the Dante controller, usually **MVR-64-xxxxxx** (with **xxxxxx** being some individual number of the multiverter), and type the following into the browser's address bar:

http://MVR-64-xxxxxx.local

Alternatively, you can type the IP address of the Dante module (as displayed in the "Network Config" tab) into the address bar, e.g. **192.168.0.204**
Please note that, depending on the network configuration, the module's IP address can be reassigned by the server.

The screenshot shows the Dante Controller web interface for a device named "MVR-64-0dbfd2". The interface includes a menu bar with "File", "Device", "View", and "Help". Below the menu bar, there are navigation tabs for "Receive", "Transmit", "Status", "Latency", "Device Config", "Network Config", and "AES67 Config". The "Network Config" tab is active, displaying the following information:

- Manufacturer Information:**
 - Manufacturer: Appsys
 - Model Name: multiverter
 - Product Version: 1.0.0
 - Software Version: 4.0.0
 - Firmware Version: 1.0.0
- Dante Information:**
 - Dante Model: Brooklyn II
 - Dante Firmware Version: 4.1.1.4
 - Hardware Version: 4.0.2.10
 - ROM/Boot Version: 1.3.71
- Clock Synchronisation:**
 - Mute Status: Unmuted
 - Sync Status: Master
 - External Word Clock: No
 - Preferred: No
 - Frequency Offset: 0 ppm
- Interfaces:**
 - IP Address: 192.168.0.204
 - Tx Utilisation: 21 Kbps Errors: 0
 - Rx Utilisation: 1 Kbps Errors: 0
 - Clear Counters

11. COMMAND LINE REFERENCE

The MVR-64 command listed below are available. Type 'help' to see this list. Most commands can be called without an argument and return the current setting.

preset [<store|recall> [<num>]]: store/recall preset number <num>

volume [<vol>]: Sets the volume of the monitor output (0-99)

monitor [<source>:<channel>]: Sets the source of the monitor output
Available sources: AD,MO,MC,MT,AE,DA,EX number:1-64

clock [<source> [<srate>|<smux>]]: Sets the clock source
Available Sources: AD,MO,MC,MT,AE,DA,EX,WCLK,INT
S.rates (for DA,INT): 44100,48000,64000,88200,96000,128000,176400,192000
SMUX (for AD,MO,MC,MT,WCLK): 1,2,4

route [<dst> [<src>]]: Routes specified channels from <src> to <dst>.
<dest>, <source> interface, channel range or number spec, either:
<if> all channels of interface <if>
<if>:<start> single channel of interface <if>
<if>:<start>-<end> channels of interface <if>, from <start> until <end>
Available sources: AD,MO,MC,MT,AE,DA,EX,NONE

When called with no params, all active routes are printed. When called with <dst> only, all routes to this destination are printed.

asrc [disable|<in> <out> <clksrc> [<srate>|<smux>]]: Configures the ASRC.

disable Turn off ASRC
<in>,<out> Interfaces which should run asynchronously. Values:
AD,MO,MC,MT,AE,DA,EX,MO+MC,MO+MT,MC+MT,AE+MT,NONE
If 'none' is specified, the ASRC is turned off for the respective direction. If both <input> and <output> are set to 'none' the ASRC is turned off.
<clksrc> Interface where the ASRC takes its clock from
<srate> Samplerate (for DA,INT), values see 'clock' command
<smux> SMUX (for AD,MO,MC,MT,WCLK): 1,2,4

function <number> [<value>]: Sets/retrieves function setting <number>

key <strokes>: Simulates keystrokes on the front panel.
<strokes> is a string consisting of one or more characters:
r(e)call,(s)toke,(r)outing,(c)lock,(m)onitor,(b)ack,(.)ok,(<)left,(>)right

version: Retrieves device version information

config [query] [json]: Set and/or get device config in JSON format.
'query' can be left out or any combination of what to get:
? query changes only since last call, must be specified as first flag in combination with any of the letter options listed below. It has the effect that unchanged options are omitted from the answer
* everything
c configuration
p parameters
r routing
s status
v version

General remote control considerations

- The app uses latest web technologies (HTML5, AJAX, Server-sent Events etc.) which require an up-to-date browser. It has been extensively tested with mid-2018 editions of Chrome, Firefox, Safari and Edge.
Older browsers - including all versions of Internet Explorer - are not supported!
- You can run up to four sessions at the same time (i.e. have the page open on four different computers). Any change or status update will propagate within a few seconds to all connected devices.
- Web control has been carefully designed to transfer data only when a change occurred (and even then only a few bytes) so it generates virtually no additional load on the Dante network.

► Command line

Command line control is available via standard telnet, and also on USB (FT232 COM port). It provides access to all multiverter functions and routings, and is perfectly suited for automated tasks.

- The telnet server listens on the Dante network, on port 2300. Use a telnet client to connect to it:

```
telnet MVR-64-xxxxxx.local 2300
```

Alternatively, you may use the IP address of the Dante module, either on the audio network or a separate control network (see Web Control).

- When connected via USB, the multiverter shows up as COM port. Communication can be done with a standard serial terminal (i.e. PuTTY or minicom). Communication parameters are 115200,8N1.
- To obtain a list of all commands, type **help** at the **MVR>** command prompt and press enter.
- To exit a command line session, type **exit** end press enter.

► MIDI

The only command understood via MIDI is "Preset Recall".
See 4.1. Preset Recall for details.

Besides this command, the MIDI port may be used to receive and transmit MIDI data in order to embed/de-embed it to any MADI stream. See 3.14. Control data forwarding for details.

3. CONNECTIONS OVERVIEW

This chapter gives you an overview of all connections on the back of the device. Please refer to 12. Specifications for full characteristics of each port.

3.1. AC Power

Mains AC inlet, 90-240VAC, 0.75A max.

Together with the DC power port, the inputs are full redundant. If any of the inputs fail, the other takes immediately over. During the switch-over process, full operational state is maintained (i.e. no interruptions in the audio flow).

3.2. DC Power

Battery / DC inlet, nominal 9-18V, tolerates up to 30V.

Maximum current 2.5A, typical operating current < 1A, standby current ca. 10mA.

Use this port

- to operate independently from AC power, e.g. from a camera battery pack in the field
- as battery backup if the AC input(s) fail. To prevent the backup battery from draining while AC power is present, keep the voltage below 16 volts.

3.3. ADAT/SPDIF/AES3 optical

Eight optical input/output ports are available. Each input and output port can be run in different modes:

- ADAT with up to 8 channels per port
- SPDIF with up to 2 channels per port
- AES3 optical with up to 2 channels per port

For the inputs, the mode is detected automatically. For the outputs, the desired mode can be set individually via the Web UI on the SETTINGS page (see 9.2 Configuration settings).

10.2. Upgrade



Firmware upgrade involves **two** operations which must be **both** carried out (order doesn't matter):

- 1) FPGA/Frontpanel (via USB and command line tool)
- 2) Dante upgrade (via Dante network connection)

1. The FPGA and Control firmware is updated via the USB port. Connect the MVR-64 via USB to your PC and run

`MVR-64-updater.bat` (on Windows)
or `sudo ./MVR-64-updater.sh` (on Linux)

and follow the instructions on the screen.

Mac users: The updater runs also in a bootcamp Windows session, when both COM ports are mapped to windows.

2. The Dante firmware is updated using the [Dante Firmware Update Manager](#) (available for Windows and Mac). The MVR must be connected to the Dante network. Select "Update Firmware" and choose the

`MVR-64-x.x.x.dnt`

file (can be found in the "firmware" folder in the firmware ZIP file).

10. FIRMWARE

10.1. Version check

We recommend to check the firmware via the Web interface ("ABOUT" tab). Only there is the overall version number (= package version, same as in the file name of the firmware ZIP-file) visible. Else you will see only component sub-versions.

► Frontpanel

Push **Recall**, move to *** Function**, confirm with **OK**, move to *** 12**, push **OK**. The different versions are shown in the 7-segment display according to Table 4: Configuration settings, index 12.

NOTE: This lists only the component sub-versions and not the overall firmware version.

► Web

Click the "ABOUT" tab. The overall firmware version number is displayed as "Firmware version: X.Y".

► Command line

Version

NOTE: This lists only the component sub-versions and not the overall firmware version.

The ports are mapped to the channels as shown in the table below. Please note that SPDIF/AES3 channel mapping is not linear, but starts with the same channel number as ADAT for each port. This allows to keep all routings the same even when the protocol changes.

Protocol	SMUX	Port							
		1	2	3	4	5	6	7	8
ADAT	x1	1..8	9..16	17..24	25..32	33..40	41..48	49..56	57..64
SPDIF / AES3	x1	1..2	9..10	17..18	25..26	33..34	41..42	49..50	57..58
ADAT	x2	1..4	5..8	9..12	13..16	17..20	21..24	25..28	29..32
SPDIF / AES3	x2	1	5	9	13	17	21	25	29
ADAT	x4	1..2	3..4	5..6	7..8	9..10	11..12	13..14	15..16
SPDIF / AES3	x4	not supported							

Table 1: Optical port channel mapping

When ADAT, SPDIF or AES3 is used as clock source, Port 1 must be connected and is used as master clock.

3.4. PC/USB

The USB port is used for firmware update, and as Remote Control Port for the PC (serial terminal, 115200, 8N1. See Command line on p.11 for details).



The USB port does NOT carry audio data!

To interface the audio system of the multiverter to a computer, connect is using Ethernet to the Dante port and use the Dante Virtual Soundcard software.

3.5. RS485

The RS485 port is prepared to send and receive Yamaha Headamp Remote control information*.

* Not implemented in firmware 4.1. Functionality will be supplied later via firmware update

3.6.

Extension

This port is designed to connect break-out boxes to support other, non-built-in protocols and standards (e.g. AVB), or to connect additional ports for system extension.

Currently supported (as of 2019-08):

Product	Purpose
MTA-64	Adapter for DiGiCo/Soundcraft/Studer/Harman MADJ-TP variant
Note: The MTA-64 uses the Extension port only for power, not for audio. The port is fed through on the MTA-64 and remains available for other extension boxes.	

Please contact us for the scheduled availability of other break-out boxes.



Two multiverters can be connected together via the extension port when a larger number of different ports is required.

Note: Although this port makes use of a standard HDMI connector, it is NOT compatible with HDMI devices. Don't connect HDMI equipment! The HDMI connector was chosen because cables are ubiquitous and can easily be replaced (and also because the electrical characteristics are perfectly suited for this purpose).

3.7.

MADI optical

This port carries MADI data, according to the "optical" transmission method specified in AES10.

The yellow LED indicates the current status:

- Off: No incoming MADI data detected
- On: Incoming MADI detected, but no valid system clock
- Flashing: Incoming MADI and valid system clock detected

Control data (e.g. for preamp control) can be forwarded over this port. See 3.14, Control data forwarding for details.



Where possible, use the "MADI optical" connection rather than BNC or TP connections to reduce the chances of noise/interference and to increase reach.

9.5.

ASRC self-test

The SRC-64 sample rate converter can be self-tested for correct operation. A 1kHz, 96k sine wave is passed through all channels of the ASRC (down-sampled to 88.2k), and looped back (up-sampled to 96k again). The result can be listened to on the headphones (and is also present on MADI optical (ch 1-32) and MADI coaxial (ch 33-64).

- Enter ASRC self-test mode by pushing **Recall**, move to ***Function**, confirm with **OK**, move to ***11**, push **OK**, turn encoder until display shows **03** and confirm with **OK**
- Plug in headphones. Turn the encoder and listen carefully to channels 1 to 64, one after another.
- On all channels a clean 1kHz tone should be audible.
- Press **Back** to exit the test.

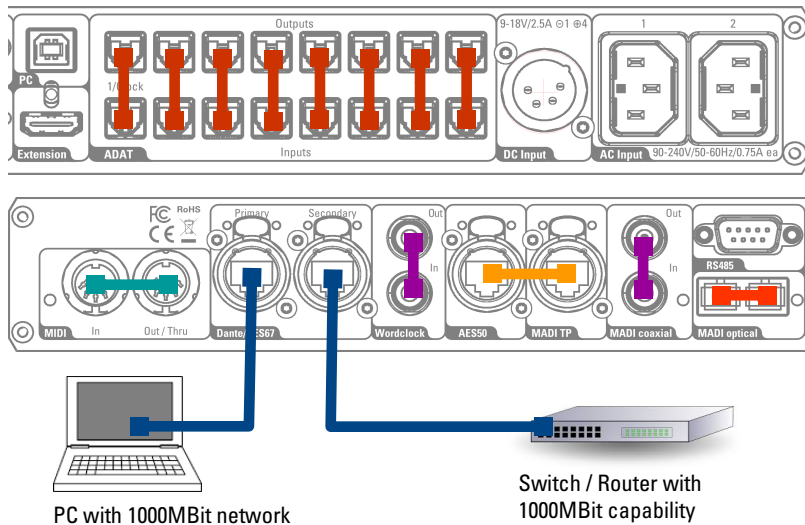

		LED indication
	8x optical TOSLINK (ADAT) cable	AD/AD
	MIDI cable (2x 5-pin DIN plug)	
	Standard 1:1 network cable	DA/DA
	BNC cable, 75 ohms	MC/MC WCLK
	AES50/MADI-TP pin swap cable, see chapter 13.1	AE/AE MT/MT
	MADI optical loop-back cable	MO/MO

Table 5: Self-test wiring

9.4. LED and button test

To verify correct operation of all LEDs and buttons,

- Enter LED/button test mode by pushing **Recall**, move to *** Function**, confirm with **OK**, move to *** 11**, push **OK**, turn encoder until display shows "02" and confirm with **OK**
- During the test, all front-panel LEDs show the same color. Each button press cycles the color, and **Back** exits the test. The seven-segment display shows **00**, **0** and **0** alternatively.
- The LEDs on the back are constantly lit during the test, except for the Dante LEDs which maintain normal operation.

3.8. MADI BNC

This port carries MADI data according to the "coaxial" transmission method specified in AES10.

The yellow LED indicates the current status:

- Off: No incoming MADI data detected
- On: Incoming MADI detected, but no valid system clock
- Flashing: Incoming MADI and valid system clock detected

Control data (e.g. for preamp control) can be forwarded over this port. See 3.14, Control data forwarding for details.

3.9. MADI TP

This port carries MADI data, according to the "MADI over Twisted Pair cabling" method specified in the draft for the upcoming AES10 standard (AES-X-213).



To interface to the **DiGiCo or Soundcraft/Studer/Harman** variants of MADI-TP, an external MTA-64 adapter is required. See

The LEDs indicates the current status:

- Yellow: Link detected
- Green: Input data valid and system clock valid

This port can also be used as second AES50 port (adapter cable and altered setting required – see 9.2 Configuration settings, and 13.1 AES50/MADI-TP Pin swap adapter cable). This second port may be used either as standalone port (48ch) or in channel aggregation mode, meaning that both AES50 ports are treated as one single interface with the first port carrying channels 1-48/1-32 (1-24/1-16@96kHz) and the second port carries channels 49-64/33-64(25-32/17-32@96kHz).

Control data (e.g. for preamp control) can be forwarded over this port. See 3.14, Control data forwarding for details.

3.10. AES50

This port carries Behringer/MIDAS compatible digital audio data (48ch@ 48kHz, 24ch@96kHz). It is also prepared to transmit control data from and to

Behringer/MIDAS preamps (i.e. for remote gain control).*

The LEDs indicates the current status:

- Yellow: Link detected
- Green: Input data valid and system clock valid

To use more than 48/24 channels with AES50, the MADI-TP port can be configured to work as second AES50 port. Use the channel-wise routing feature from the Web remote to map the channels as required.



This port can also be switched to work as second MADI-TP port (see 9.2 Configuration settings, and 13.1 AES50/MADI-TP Pin swap adapter cable). In MADI-TP mode, Control data (e.g. for preamp control) can be forwarded over this port. See 3.14, Control data forwarding for details.

3.11.

Wordclock

The wordclock *input* accepts a square wave signal in the frequency of the sample rate. X2 and X4 modes are automatically detected when the square wave has X2/X4 frequency, and can be manually set when the square wave has X1 frequency.

A 75 ohms termination resistor can internally be switched but is OFF by default. Altering the setting requires opening of the device, please contact us for further information.

The wordclock *output* is a square wave signal (50% duty cycle) and is able to drive up to two 75 ohm resistors in parallel. Its frequency is either identical to the sample rate or always x1 (see 9.2 Configuration settings).

3.12.

Dante/AES67

The "Primary" and "Secondary" ports are standard gigabit Ethernet ports, designed to connect to Dante Digital Audio Network. AES67 mode is alternative to Dante mode and can be set in the Dante Controller Software.

* Not implemented in firmware 4.1. Functionality will be supplied later via firmware update.

9.3. Audio Interface self-test

The MVR-64 can check itself for correct operation. This is done by sending a special signal out on every interface through an external loop back and monitor LED on the front panel turns green. When the received data is correct, the respective LED on the front panel turns green.

To perform the self-test,

- Connect the cables in loop-back mode as shown below
- NOTE: If you want to test a specific interface only, it is sufficient to wire the loop-back on that interface only and monitor the respective LED
- Enter self-test mode by pushing **Recall**, move to ***Function**, confirm with **OK**, move to ***11**, push **OK**, turn encoder until display shows **01** and confirm with **OK**
- On the headphones output, a 1kHz sine wave is played on both channels. During the self-test, **5F** is shown in the seven-segment display. To return to normal operation, press **Back**

Table 4: Configuration settings

Index	Purpose	Values (bold: default setting)																		
[12]	Version info	<p>Note: The firmware consists of several different parts. To check the overall firmware version number, use the web interface.</p> <p>Turn the encoder left or right to display the different version numbers in the 7-segment display:</p> <table border="0"> <tr> <td>*AD</td> <td>FFGA Firmware Major version</td> </tr> <tr> <td>*MO</td> <td>FFGA Firmware Minor version</td> </tr> <tr> <td>*MC</td> <td>Control Firmware Major version</td> </tr> <tr> <td>*MT</td> <td>Control Firmware Minor version</td> </tr> <tr> <td>*AE</td> <td>Hardware version Mainboard</td> </tr> <tr> <td>*DA</td> <td>Hardware version Front panel</td> </tr> <tr> <td>*EX</td> <td>ASRC Firmware Major version ("--" if not installed)</td> </tr> <tr> <td>*CH</td> <td>ASRC Firmware Minor version ("-" if not installed)</td> </tr> <tr> <td>*Vol</td> <td>Hardware version ASRC ("-" if not installed)</td> </tr> </table>	*AD	FFGA Firmware Major version	*MO	FFGA Firmware Minor version	*MC	Control Firmware Major version	*MT	Control Firmware Minor version	*AE	Hardware version Mainboard	*DA	Hardware version Front panel	*EX	ASRC Firmware Major version ("--" if not installed)	*CH	ASRC Firmware Minor version ("-" if not installed)	*Vol	Hardware version ASRC ("-" if not installed)
*AD	FFGA Firmware Major version																			
*MO	FFGA Firmware Minor version																			
*MC	Control Firmware Major version																			
*MT	Control Firmware Minor version																			
*AE	Hardware version Mainboard																			
*DA	Hardware version Front panel																			
*EX	ASRC Firmware Major version ("--" if not installed)																			
*CH	ASRC Firmware Minor version ("-" if not installed)																			
*Vol	Hardware version ASRC ("-" if not installed)																			
[13]	ADAT transmit modes	<p>Note: Cannot be configured from the front panel - use Web UI instead!</p> <p>ADAT: 8 channels ADAT format SPDIF: 2 channels (stereo), header in consumer format AES3: 2 channels (stereo), header in professional format</p> <p>Possible values: Sets the output mode for each ADAT port.</p> <p>Press Back to exit the version display mode.</p>																		

Index	Purpose	Values (bold: default setting)																																																																									
		<table border="1"> <tr> <td>13 ‡</td> <td rowspan="3">Studer</td> <td>96k</td> <td rowspan="15">MDIX (Crossover)</td> </tr> <tr> <td>14 ‡</td> <td>64</td> <td>48k</td> </tr> <tr> <td>15 ‡</td> <td></td> <td>96k</td> </tr> <tr> <td>24 ‡</td> <td rowspan="3">DiGiCo</td> <td>56</td> <td>48k</td> </tr> <tr> <td>25 ‡</td> <td></td> <td>96k</td> </tr> <tr> <td>26 ‡</td> <td>64</td> <td>48k</td> </tr> <tr> <td>27 ‡</td> <td></td> <td>96k</td> <td></td> </tr> <tr> <td>28 ‡</td> <td rowspan="3">Soundcraft/ Studer</td> <td>56</td> <td>48k</td> </tr> <tr> <td>29 ‡</td> <td></td> <td>96k</td> </tr> <tr> <td>30 ‡</td> <td>64</td> <td>48k</td> </tr> <tr> <td>31 ‡</td> <td></td> <td>96k</td> <td></td> </tr> <tr> <td>32</td> <td rowspan="2">AES-X213</td> <td>57</td> <td>48k</td> <td rowspan="2">Auto</td> </tr> <tr> <td>33</td> <td></td> <td>96k</td> </tr> <tr> <td>40 ‡</td> <td rowspan="2">DiGiCo</td> <td rowspan="2">57</td> <td>48k</td> <td rowspan="10">Straight</td> <td rowspan="10">MTA-64 required</td> </tr> <tr> <td>41 ‡</td> <td>96k</td> </tr> <tr> <td>44 ‡</td> <td rowspan="2">Soundcraft/ Studer</td> <td rowspan="2">57</td> <td>48k</td> </tr> <tr> <td>45 ‡</td> <td>96k</td> </tr> <tr> <td>56 ‡</td> <td rowspan="2">DiGiCo</td> <td rowspan="2">57</td> <td>48k</td> <td rowspan="2">MDIX (Crossover)</td> </tr> <tr> <td>57 ‡</td> <td>96k</td> </tr> <tr> <td>60 ‡</td> <td rowspan="2">Soundcraft/ Studer</td> <td rowspan="2">57</td> <td>48k</td> </tr> <tr> <td>61 ‡</td> <td>96k</td> </tr> </table>	13 ‡	Studer	96k	MDIX (Crossover)	14 ‡	64	48k	15 ‡		96k	24 ‡	DiGiCo	56	48k	25 ‡		96k	26 ‡	64	48k	27 ‡		96k		28 ‡	Soundcraft/ Studer	56	48k	29 ‡		96k	30 ‡	64	48k	31 ‡		96k		32	AES-X213	57	48k	Auto	33		96k	40 ‡	DiGiCo	57	48k	Straight	MTA-64 required	41 ‡	96k	44 ‡	Soundcraft/ Studer	57	48k	45 ‡	96k	56 ‡	DiGiCo	57	48k	MDIX (Crossover)	57 ‡	96k	60 ‡	Soundcraft/ Studer	57	48k	61 ‡	96k
13 ‡	Studer	96k	MDIX (Crossover)																																																																								
14 ‡		64			48k																																																																						
15 ‡				96k																																																																							
24 ‡	DiGiCo	56		48k																																																																							
25 ‡				96k																																																																							
26 ‡		64		48k																																																																							
27 ‡		96k																																																																									
28 ‡	Soundcraft/ Studer	56		48k																																																																							
29 ‡				96k																																																																							
30 ‡		64		48k																																																																							
31 ‡		96k																																																																									
32	AES-X213	57		48k	Auto																																																																						
33				96k																																																																							
40 ‡	DiGiCo	57		48k	Straight		MTA-64 required																																																																				
41 ‡				96k																																																																							
44 ‡	Soundcraft/ Studer	57	48k																																																																								
45 ‡			96k																																																																								
56 ‡	DiGiCo	57	48k	MDIX (Crossover)																																																																							
57 ‡			96k																																																																								
60 ‡	Soundcraft/ Studer	57	48k																																																																								
61 ‡			96k																																																																								
		‡: MTA-64 adapter required																																																																									
		General: Using the MADI-TP port as AES50 or vice versa is possible, but requires a pinswap cable (see chapter 13.1) due to the different pinout.																																																																									
[06]	Wordclock output mode	*00 = Wordclock output frequency identical to sample rate 01 = Wordclock output frequency is always single speed (base sample rate)																																																																									
[07]	MIDI channel	01...16. Default: 01. NOTE: This is a per-preset setting: remember to change on all presets!																																																																									
[08]	MIDI forwarding	Configures from/to which MADI interface the data on the MIDI jacks is routed. *00 = Disabled 01 = MADI optical 02 = MADI coaxial 03 = MADI-TP 04 = AES50 (in MADI-TP mode only)																																																																									
[09]	Reserved																																																																										
[10]	Display brightness	01...05. Default: 05																																																																									
[11]	Service menu	01 = Self-test (external cabling required, see 9.5. Audio Interface self-test) 02 = LED and button test. See 9.6. LED and button test 03 = ASRC self-test. See 9.7 ASRC self-test 99 = Reset to Factory Defaults																																																																									



The Dante port provides also the Web UI and a telnet server (on port 2300) for remote control. Both services are available on the same IP address as the Dante audio interface (use the Dante Controller software to determine or change the IP).

- The port LEDs indicates the current status:
- Yellow: Link detected
 - Green: Input data valid and system clock valid

Please refer to the [Audinate website](#) for information about Dante Technology, the latest Dante Controller drivers and related information.

By default, the ports are configured to act as switch (which allows daisy chaining), but can be changed using the Dante Controller Software as redundant ports for parallel connection.

3.13. MIDI

The only command supported via the MIDI port is "Preset Recall". See 4.1 Preset Recall.

The yellow LED near the port flashes when incoming MIDI data is detected. All incoming data is forwarded to the MIDI THRU port, to allow daisy-chaining of devices.

Control data (e.g. for preamp control) can be forwarded over this port. See 3.14, Control data forwarding for details.

3.14. Control data forwarding

The multiverter is able to forward control data (headamp/stagebox control) between MADI ports, and from and to the MIDI ports. The multiverter provides transparent forwarding of all extra AES3 bits (V)alid, (U)ser data and (C)hannel status, which makes it compatible to all vendor-specific remoting protocols.

To enable remoting, the channels containing the control data must be routed 1:1 (i.e. linearly), depending on the vendor protocol.

Index	Purpose	Values (bold: default setting)																											
[01]	Headphones mode	<table border="1"> <thead> <tr> <th>Value</th> <th>Mode</th> <th>Extra Gain</th> </tr> </thead> <tbody> <tr> <td>*01</td> <td>Mono</td> <td>+0dB (none)</td> </tr> <tr> <td>02</td> <td>Stereo</td> <td></td> </tr> <tr> <td>03</td> <td>Mono</td> <td>+6dB</td> </tr> <tr> <td>04</td> <td>Stereo</td> <td></td> </tr> <tr> <td>05</td> <td>Mono</td> <td>+12dB</td> </tr> <tr> <td>06</td> <td>Stereo</td> <td></td> </tr> <tr> <td>07</td> <td>Mono</td> <td>+24dB</td> </tr> <tr> <td>08</td> <td>Stereo</td> <td></td> </tr> </tbody> </table> <p>Mono: Both L and R speakers of the headphones play the same monitor channel. The channel indication ranges from 1 to 64 and changes in steps of 1.</p> <p>Stereo: Odd channels are played on the L speaker and the subsequent channel is played on the R speaker. The channel indication ranges from 1 to 63 and changes in steps of 2</p> <p>Extra gain may cause clipping on large signals.</p>	Value	Mode	Extra Gain	*01	Mono	+0dB (none)	02	Stereo		03	Mono	+6dB	04	Stereo		05	Mono	+12dB	06	Stereo		07	Mono	+24dB	08	Stereo	
Value	Mode	Extra Gain																											
*01	Mono	+0dB (none)																											
02	Stereo																												
03	Mono	+6dB																											
04	Stereo																												
05	Mono	+12dB																											
06	Stereo																												
07	Mono	+24dB																											
08	Stereo																												
[02]	MADI optical transmit mode ¹	Value Number of channels 96k frame format																											
[03]	MADI coaxial transmit mode ¹	Value Number of channels 96k frame format																											
[04]	MADI-TP port operation mode	Value Mode Num. 96k frame format Pinout Remarks																											
[05]	AES50 port operation mode	Value Mode Num. 96k frame format Pinout Remarks																											

¹ Setting applies only to transmit function. Receive data format is automatically detected depending on the clock settings.

Vendor	Control method
DIGiCo	Control data is contained in all bits (audio+user) of channel 57. To enable forwarding between different MADI ports, • Set MADI transmit mode of the involved MADI ports to 57ch (see 9.2 Configuration settings) • Route ch 57 to ch 57 both ways
Soundcraft	Control data is contained in the "U" bit of channels 1..10. ch 1..10 both ways • To enable forwarding between different MADI ports, route ch 1..10 to
RME, FerroFish, DirectOut (MIDI over MADI)	Control data is contained in the "U" bit of channel 56 (ch28 in 96k mode) • To enable forwarding between different MADI ports, route ch 56 to ch 56 both ways. • To enable forwarding from/to the MIDI ports on the rear to/from a particular MADI port, set "[08] MIDI forwarding" to the desired MADI port (see 9.2 Configuration settings)

Table 2: Remote control over MADI

- Confirm by pushing the encoder (or push **Back** to cancel the operation)
- The current value is displayed in the 7-segment display. Rotate the encoder to change the value, and push it to confirm.

► Web

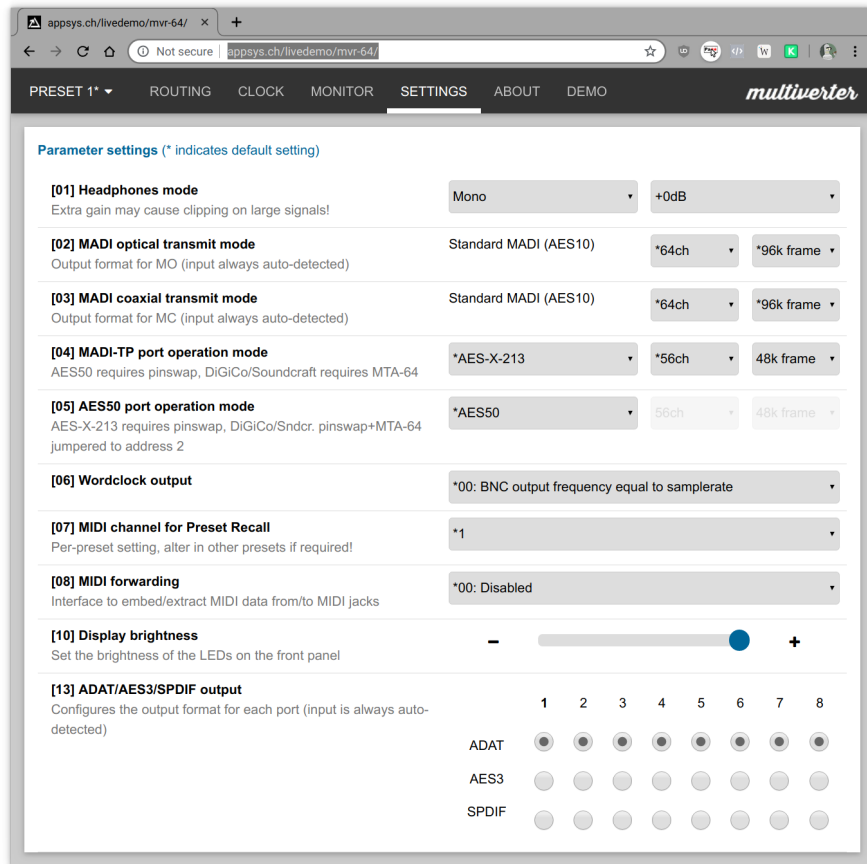

The "SETTINGS" page contains various fine-tuning parameters. An asterisk * indicates the default setting

► Command line

`function <number> [<value>]`

4. PRESETS

All settings (excluding headphones level) can be individually stored in one of the 12 preset locations, and may be recalled at any time later. The settings are stored in non-volatile memory and are retained for years even if the device is switched off or the power cable is unplugged. Additionally, the settings can be downloaded via the Web UI, and restored on the same or a different device.

4.1. Preset Recall

► Front panel

To recall a preset:

- Push the **Recall** button from the "Preset" menu.
- Select the desired storage location ***1** to ***12** by turning the encoder left or right.
- Note: The presets "Test tone" and "Function" have special purposes. See 9. Advanced Topics.
- Confirm the selected location by pushing the encoder, or push the **Back** button to cancel the operation.

► Web

From the "PRESET ▼" menu, choose the desired preset number. An asterisk next to the number indicates that modifications to the recalled preset have been done. To save the modifications, choose "PRESET / Store".

Note: You can also upload presets from a file to the MVR. This is useful when transferring setups between different multiverterers.

► Command line

`preset recall <num>`

► MIDI

Preset recall is done via "Program Change" messages (program 00 = Preset 1 ... program 11 = Preset 12).

The MIDI channel is set to 1 by default but can be altered using function "07". (Note: The channel is a per-preset setting, if you need to change it you will need to do so in all 12 presets).

4.2. Preset Store

- **Front panel**
- To store a preset: Push the **Store** button in the "Preset" menu.
 - Select the desired storage location *** 1** to *** 12** by turning the encoder left or right.
 - Confirm the selected location by pushing the encoder, or push the **Back** button to cancel the operation.
- **Web**
- Select "PRESET ▲ / Store" menu to store the preset as current preset number, or select "PRESET ▲ / Store as..." to choose a different number.
- Note: You can also download presets to a file. This is useful when transferring setups between different multiverterers.

- **Command line**
- preset store [<num>]

4.3.

Changed presets

► **Front panel**

When a preset is recalled, the corresponding location *** 1** to *** 12** is lit green. If any setting is changed afterwards (except for headphones level), the LED turns red to indicate that the current setting differs from the recalled preset. If you want your changes to be reflected also in the stored preset, just store the preset again. Otherwise, the changes are overwritten the next time a preset is recalled.

► **Web**

A changed preset is indicated by an asterisk (*) next to the preset number. Use "PRESET ▲ / Store" to permanently store changes into that preset.

► **Command line**

A changed preset is indicated by an asterisk (*) next to the preset number. The current preset can be queried by calling **preset** without parameters.

9. ADVANCED TOPICS

9.1.

Test tone mode

► **Front panel only**

For diagnostic purposes, the multiverter is able to play a test tone (1 kHz, -20dB sine wave) on all outputs which are currently active. This feature is especially helpful to determine problems in your signal flow, as it does not rely on any external sources (except for the clock).

- To enter test tone mode:
- Push the blue **Recall** button
 - Move the cursor to *** Test tone** by turning the encoder left or right
 - Confirm your selection by pushing the encoder, or push **Back** to cancel the operation.
 - The test tone mode is now active. All outputs which are active in the Routing matrix are replaced by the test tone signal (indicated by yellow lit LEDs in the Routing area).
- To exit test tone mode:
- Push the blue **Recall** button
 - Move the cursor to "Test tone" by turning the encoder left or right
 - De-select Test tone mode by pushing the encoder, or push **Back** to cancel the operation.

9.2.

Configuration settings

The multiverter offers fine-tuning of various parameters and seldom used settings via the "Function" item in the Preset menu, or via the web interface. The "index" indicates the parameter to change, while the corresponding "value" reflects its current setting. **A complete list of "index/value" pairs can be found in the table below.**

► **Front panel**

- The "function index" is indicated by *** 1** to *** 12** in the "Preset" menu, while the corresponding "value" is displayed in the 7-segment display.
- To adjust a particular setting:
- Push the blue **Recall** button
 - Move the cursor to *** Function** by turning the encoder left or right
 - Confirm by pushing the encoder (or push **Back** to cancel the operation).
 - The *** Function** LED should now be lit.
 - Move the cursor to the desired index *** 1** to *** 12**

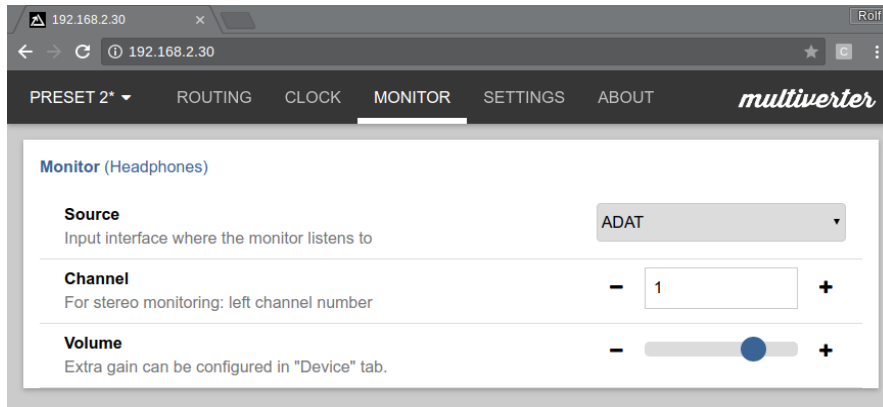

The "MONITOR" page allows to set the source interface, channel and volume for the headphones. More settings (stereo/mono mode, gain) can be found on the "SETTINGS" page.

► Command line

monitor [<source>:<channel>]

Sets the source interface and channel. If stereo monitoring is selected, <channel> corresponds to the "L" channel, the subsequent channel is output as "R" signal.

volume [<vol>|+|-]

Sets the volume of the monitor output, either as <vol> from 0-99, or "+" to increment / "-" to decrement the volume by 1.

4.4. Auto-Store

In addition to the presets stored in locations 1-12, the multiverter remembers **always** the current setting, even when power cycled or left unpowered for a long time. This means that you can always reset the multiverter and have the settings fully restored by switching it off and on.

5. ROUTING

Due to a lack of controls, the front panel allows only interface-wise routing. To use channel-wise routing (merging of different input streams), use either the web interface or the command line.



Front panel

- The routing matrix indicates the interfaces between conversions are currently active.
- A green LED means that a connection is made between the two interfaces, and a conversion is currently in progress.
 - A red LED means that a connection is made, but inactive because the input or clock signals are missing.
 - A yellow LED means that a test tone is currently output instead of the input signal.

Routing is easy if you think this way:



"I want this input mapped to this output"

- To make or break a connection in the Routing matrix:
- Push the **Set** button in the "Routing" menu
 - A yellow blinking cursor indicates the current position within the matrix. Move it by turning the encoder to the desired point where you want to make or break a connection.
 - At the beginning or end of the line, continue to turn to the right to make the cursor wrap around to the previous or next line.
 - Push the encoder or press the **Set** button to make/break a connection.
 - When the cursor blinks yellow/red or yellow/green, the connection has been made; when the cursor blinks yellow/dark, the connection was broken.
 - To exit the routing matrix, push the **Back** button.

Web

The web interface allows fine-grained routing control in different levels (whole interfaces, channel groups or single channels). Routes can be entered via either *Matrix* or *List* view (both can be used interchangeably, and routings established in one view show immediately up also in the other).

8. MONITOR

The "Monitor" section controls the headphone amplifier which allows you to listen to any channel received on the inputs.

You can adjust if mono (same channel on both ears) or stereo signals are output on the headphones. Also, extra gain (+6/+12/+24dB) can be added for the headphones output to ease monitoring of silent signals (but may cause clipping at larger levels).



To adjust these settings, see [9.2. Configuration settings](#)

Front panel

To select a particular input to listen to:

- Press the **Set** button in the "Monitor" menu.
- Move the yellow blinking cursor to the desired interface.
- Push the encoder or press the **Set** button to select the interface, or press **Back** to cancel.

To select a channel:

- Make sure that **Ch** mode is selected. If not, push the encoder once.
- Rotate the encoder left to decrease the channel, or right to increase the channel.
- In stereo mode, the selected channel is output on "L" whereas the subsequent channel is output on "R".

To change the volume:

- Make sure that **Vol** mode is selected. If not, push the encoder once.
- Rotate the encoder left to decrease the volume, or right to increase the volume.

Web

7. PANEL LOCK

► Front panel

The panel lock feature can be used to disable all buttons on the front panel. This can be used to protect the MVR-64 against undesired or accidental parameter changes. The panel lock feature is available from firmware version 1.4 and higher.

- To lock the panel, hold down the **Back** button while pushing the encoder. The seven-segment display will blink to indicate the now locked panel. All buttons on the front panel are now disabled.
- If a button is pressed while the panel is locked, the seven-segment display will blink to indicate the locked panel.
- To unlock the panel, hold down the **Back** button while pushing the encoder.

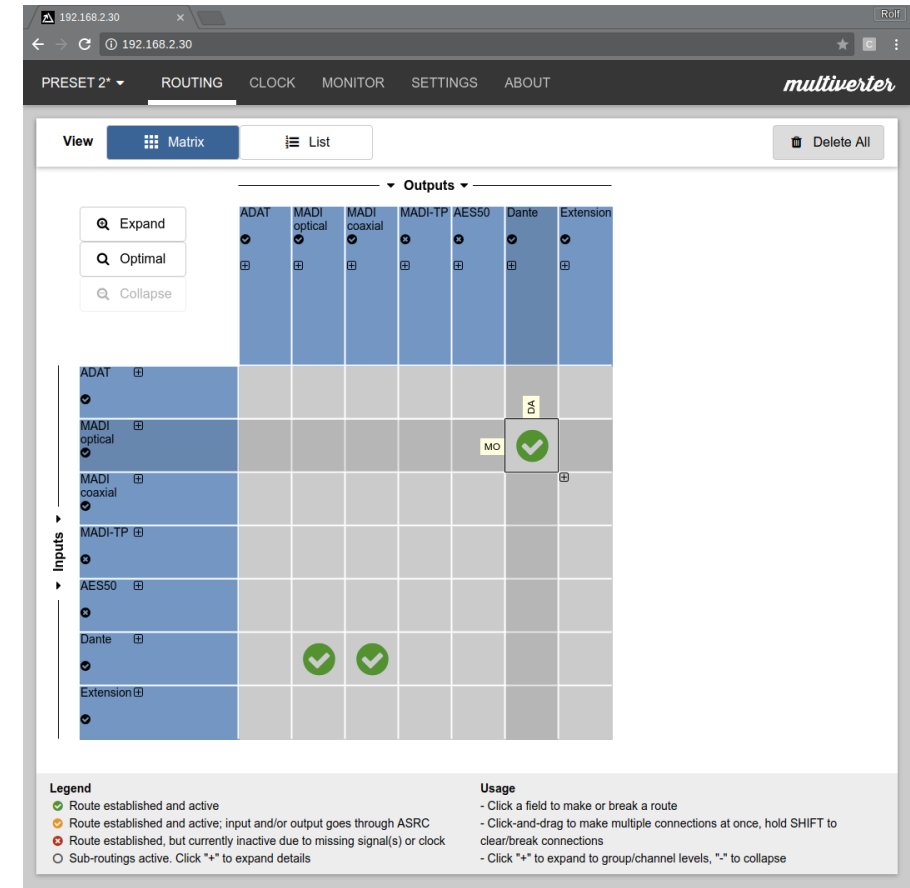

Matrix view: ideal for quick routings, everything on one glance. The arrangement is the same as on the front panel

- Click anywhere in the matrix to make or break a connection. Multiple connections can be made by click-and-drag, broken by holding SHIFT.
- Current status of a connection is indicated by the large colored icon on the connection; current status of each input / output is indicated smaller on the header.
- The matrix can be expanded to group- and channel-wise views via **+** and **-** buttons on rows (inputs), columns (outputs) or intersections (connections).
- The "Expand" and "Collapse" buttons zoom the entire matrix. Use the "Optimal" button to expand to all sub-routings.
- To clear all connections, click "Delete All".

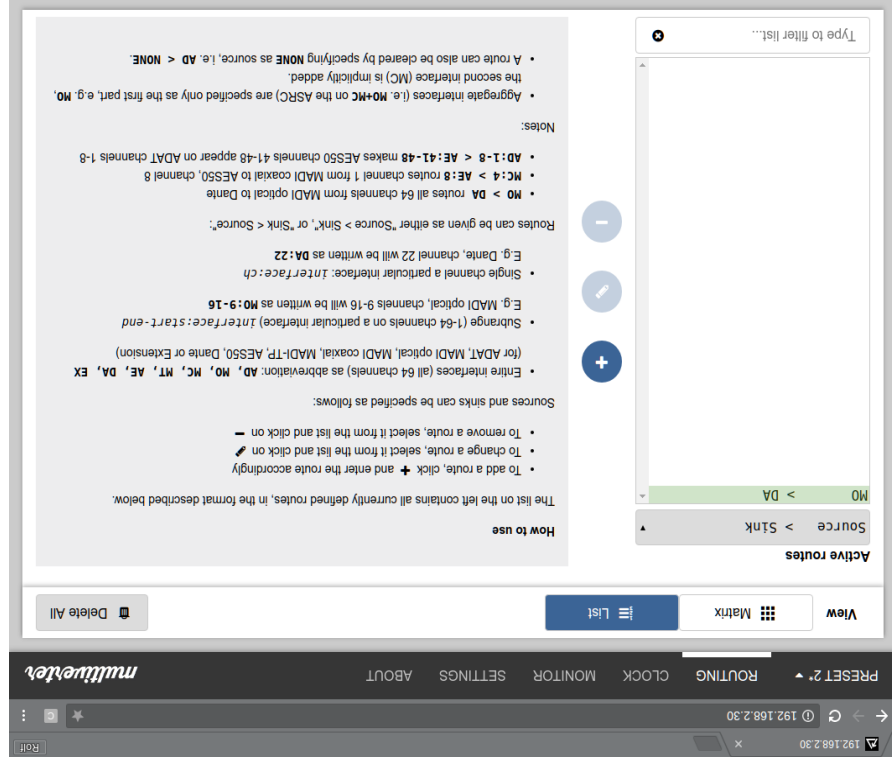

List view: quick way to establish complex routings

- Each routing can be entered as text line, in the form "Source > Sink" or alternatively "Sink > Source" (both produce identical results).
- "Sink" and "Source" can be entire interfaces, channel ranges or single channels. Entire interfaces are specified as two-letter abbreviation (i.e. "MO" for MAD1 optical)
- Channel ranges can be specified by appending a colon, followed by the start and end channels. For example, Dante channel 9 to 16 would read "DA:9-16"
- Single channels are specified by appending a single the channel number to an interface, separated by a colon. For example, AES50 channel 24 would read "AE:24"
- Example 1: to route all channels from AES50 to MAD1 coaxial, enter "AE > MC" (or alternatively, "MC > AE")
- Example 2: to route channels Dante 56-64 to ADAT channels 1-8, enter "DA:56-64 > AD:1-8" (or alternatively, "AD:1-8 > DA:56-64")
- Example 3: to route MAD1 TP channel 2 to Extension channel 1: "MT:2 > EX:1" (or alternatively, "EX:1 > MT:2")

6.3.

Dante Clock

The Dante network itself needs one device which acts as "Network clock master" (not to be confused with the system clock master, which may also be a different device!)
 The selection of the network clock master can be done in the Dante Controller software, and must be done depending on the multiverter's main clock source:

multiverter clock source (set on multiverter)	Dante module *DA	any Dante node (except Dante Virtual Soundcard)	only multiverter possible
--	------------------	---	---------------------------

Table 3: Dante clocking modes

- Samplerate (only required for DA or INT):
44100,48000,64000,88200,96000,128000,176400,192000
- SMUX (only required for AD,MO,MC,MT or WCLK): 1,2,4
- asrc [disable|<in> <out> <clksrc> [<srate>|<smux>]]
- disable Turn off ASRC
- <in>,<out> Interfaces which should run asynchronously.
- Values: AD,MO,MC,MT,AE,DA,EX,MO+MC,MO+MT,MC+MT,AE+MT,NONE
- If NONE is specified, the ASRC is turned off for the respective direction. If both <in> and <out> are set to NONE the ASRC is turned off.
- <clksrc> Interface where the ASRC takes its clock from
- <srate> Samplerate (for DA,INT), values see 'clock' command
- <smux> SMUX (for AD,MO,MC,MT,WCLK): 1,2,4

► Web

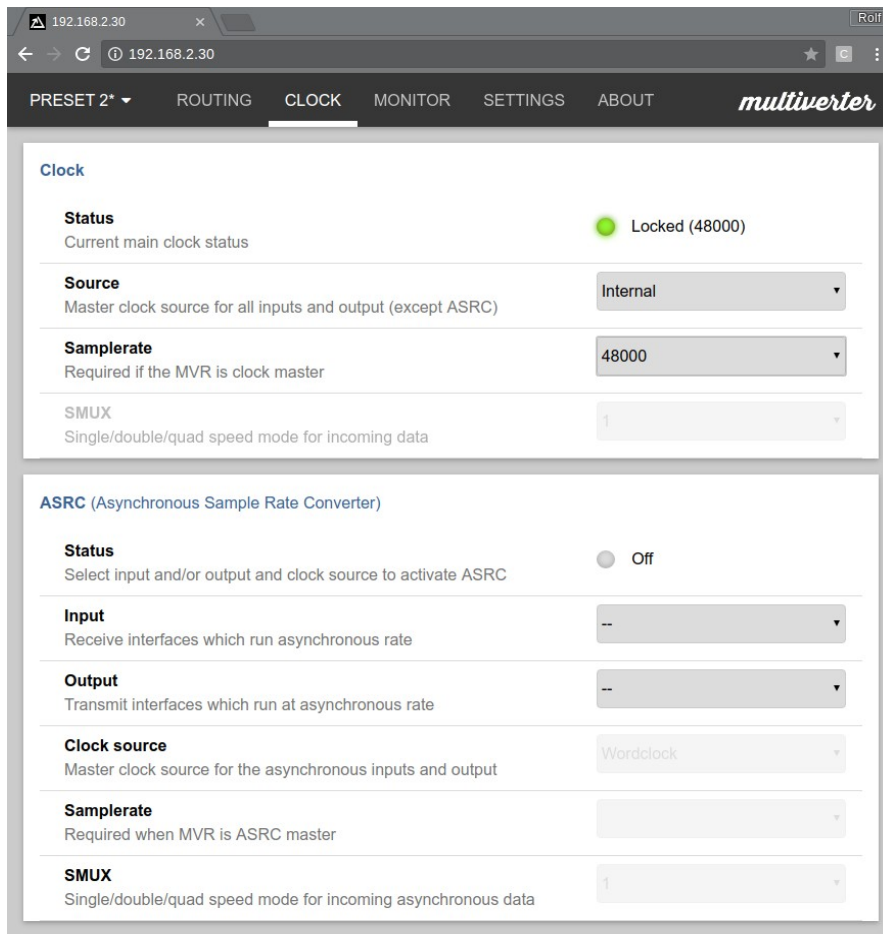

Clock

Status
Current main clock status ● Locked (48000)

Source
Master clock source for all inputs and output (except ASRC) Internal

Samplerate
Required if the MVR is clock master 48000

SMUX
Single/double/quad speed mode for incoming data 1

ASRC (Asynchronous Sample Rate Converter)

Status
Select input and/or output and clock source to activate ASRC Off

Input
Receive interfaces which run asynchronous rate --

Output
Transmit interfaces which run at asynchronous rate --

Clock source
Master clock source for the asynchronous inputs and output Wordclock

Samplerate
Required when MVR is ASRC master

SMUX
Single/double/quad speed mode for incoming asynchronous data 1

The main clock parameters can be configured on the "CLOCK" page. When the ASRC module is installed, its behavior (asynchronous interfaces etc.) can be selected in the ASRC section on the bottom.

► Command line

```
clock [<source> [<srate>|<smux>]]
```

- Available Sources: AD,MO,MC,MT,AE,DA,EX,WCLK,INT

► Command line

```
route <destination> [<source>]
```

with <destination> and <source> indicating channel ranges as described in the "List view" section above. If <source> is omitted, the current source for <destination> is printed.

6. CLOCKING

All components within a digital audio system must reference to the same master clock to ensure that they run synchronously. The multivertex can use any of the incoming interfaces as clock source, or alternatively it can act as clock master using its internal, high-quality clock synthesizer.

If a common clock is not possible (e.g. when incoming data has a different sample rate), the optional **ASRC module** can be used to convert the data to the multivertex's main clock.



See the [ASRC manual](#) for details.

6.1.

ClockShield

The multivertex's unique **ClockShield** feature allows the device to run up to one second (!) without a master clock signal. This makes the multivertex very robust against disturbances, glitches and dropouts in the clocking system.

How it works:

- When the clock signal is lost, the multivertex's clock continues to run for up to one second, at the frequency which it has been locked to when the clock was valid. During that period, audio processing continues as before.

- When the clock signal is re-applied, re-synchronization takes place to ensure perfect bit-wise alignment of data and clock. To avoid pops and clicks, all audio signals are soft-muted before the re-sync happens, and are soft unmuted directly after re-sync. The whole process takes only a few milliseconds and produces only minimal artifacts, often not even audible.



ClockShield is supported on all interfaces, but works best when the multivertex is clocked from the BNC wordclock input.

6.2. Clock source selection

▶ Front panel

- To set the **main** clock source:
 - Push the **Set** button in the "Clock" menu.
 - Move the yellow blinking cursor to the desired clock source.
 - Push the encoder or press the **Set** button to select the interface, or press **Back** to cancel.
 - Depending on the selection, you will be asked to provide additional information:
 - When the clock source is set to internal ***INT**, you will be asked for the sample frequency where the internal clock should run at. Choose one from the ***32kHz** to ***192kHz**, or press **Back** to return to the clock source selection. **NOTE:** Not all sample rates (especially the 32/64/128kHz modes) are available on all interfaces.
 - When MAD1 optical ***MO**, MAD1 coaxial ***MC**, MAD1-TP ***MT** or BNC wordclock ***WCLK** is chosen, you need to set whether the multivertex should run in x1 (32/44.1/48kHz), in x2 (64/88.2/96kHz) or in x4 (128/176.4/192kHz). Choose the desired mode and push the encoder to confirm, or press return to the clock source selection.
- Note: Regardless of the selection, the multivertex will always run in x2 mode when MAD1 96k frames are received.